

## COOKIE 4 legs

5007-4LGP

Design Studio Zetass

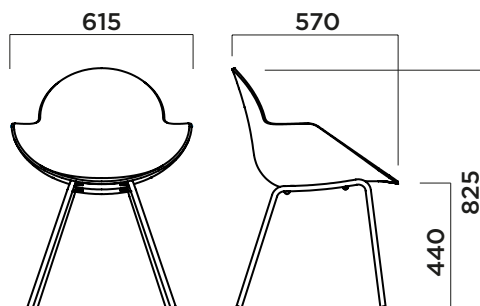

### FRAME

TELAIO  
BASTIDOR

Metal frame in round tube diameter 18 mm, thickness 2 mm, accordingly with UNI EN 10305-3 rule in Asform.

Telaio in metallo con tubo tondo di diametro 18mm, spessore 2mm, prodotto secondo la norma UNI EN 10305-3 in Asform.

Bastidor metálico de tubo redondo de 18 mm de diámetro y 2 mm de espesor, conforme a la norma UNI EN 10305-3 en Asform.



01



30



31

### SHELL

SCOCCA  
CARCASA

Polypropylene + Glass fiber

Polipropilene + Fibra di vetro

Polipropileno + Fibra de vidrio



S020



S503



P421C



P480C



S011

### FINISHING

FINITURA  
ACABADO

Painted frame with epoxy-polyester powder with average thickness of 50  $\mu$ . Chromed frame with average thickness of 5  $\mu$ .

Telaio verniciato con polveri epossi-poliesteri spessore medio di 50  $\mu$ . Telaio cromato con spessore medio 5  $\mu$ .

Bastidor con recubrimiento en polvo epoxi-poliéster con 50  $\mu$  de espesor medio. Bastidor cromado con 5  $\mu$  de espesor medio.

### FEET

PIEDINI  
PIES DE APOYO

Polypropylene

Polipropilene

Polipropileno

### PKG

IMBALLO  
EMBALAJE

Pkg	A(cm)	B(cm)	h(cm)	MC	PCS	Weight (kg)
59	63	85.5	0.32	1	13.3	

## COOKIE 4 legs upholstered

5007-4LGT

Design Studio Zetass

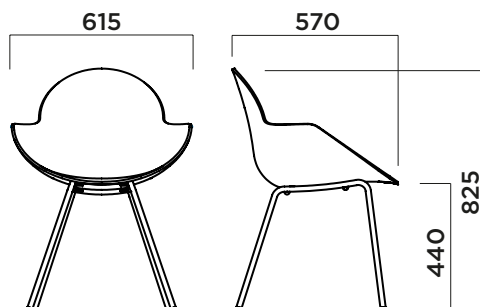

### FRAME

TELAIO  
BASTIDOR

Metal frame in round tube diameter 18 mm, thickness 2 mm, accordingly with UNI EN 10305-3 rule in Asform.

Telaio in metallo con tubo tondo di diametro 18mm, spessore 2mm, prodotto secondo la norma UNI EN 10305-3 in Asform.

Bastidor metálico de tubo redondo de 18 mm de diámetro y 2 mm de espesor, conforme a la norma UNI EN 10305-3 en Asform.



01

30

31

### UPHOLSTERY

TAPPEZZERIA  
TAPIZADOS

Upholstered shell.

Scocca tappezzata

Upholstered shell.

- A Space, Panarea
- B Eco Leather
- C Convert D, Velvety, Step, Step Melange, Nuvole
- D Reflect
- E Oceanic , Yoredale
- F Canvas2
- G Fiord, Patio

COM Fabric(m)    COM Leather(m2)

1.10

1.70

### PKG

IMBALLO  
EMBALAJE

Pkg	A(cm)	B(cm)	h(cm)	MC	PCS	Weight (kg)
	59	63	85.5	0.32	1	14.2

## COOKIE wooden legs

5007-WLGP

Design Studio Zetass

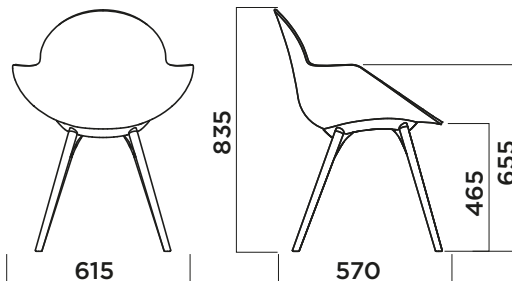

### WOODEN LEGS

GAMBE LEGNO

PATAS DE MADERA

Solid natural beech

Faggio massello naturale

Haya natural maciza



**FGVAN**



**FGLP04G**



**FGLP06G**

### SHELL

SCOCCA

CARCASA

Polypropylene + Glass fiber

Polipropilene + Fibra di vetro

Polipropileno + Fibra de vidrio



**S020**



**S503**



**P421C**



**P480C**



**S011**

### FEET

PIEDINI

PIES DE APOYO

Polypropylene

Polipropilene

Polipropileno

### PKG

IMBALLO

EMBALAJE

Pkg	A(cm)	B(cm)	h(cm)	MC	PCS	Weight (kg)
	59	63	85.5	0.32	1	13.3

## COOKIE wooden legs upholstered

5007-WLGT

Design Studio Zetass

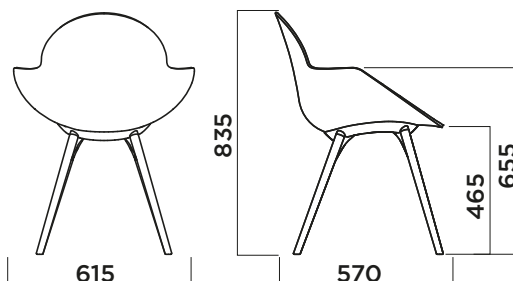

### WOODEN LEGS

GAMBE LEGNO

PATAS DE MADERA

Solid natural beech

Faggio massello naturale

Haya natural maciza



**FGVAN**



**FGLP04G**



**FGLP06G**

### UPHOLSTERY

TAPPEZZERIA

TAPIZADOS

Upholstered shell.

Scocca tappezzata

Upholstered shell.

- A** Space, Panarea
- B** Eco Leather
- C** Convert D, Velvety, Step, Step Melange, Nuvole
- D** Reflect
- E** Oceanic , Yoredale
- F** Canvas2
- G** Fiord, Patio

**COM Fabric(m)**    **COM Leather(m2)**

1,10

1,70

### FEET

PIEDINI

PIES DE APOYO

Polypropylene

Polipropilene

Polipropileno

### PKG

IMBALLO

EMBALAJE

Pkg	A(cm)	B(cm)	h(cm)	MC	PCS	Weight (kg)
59	63	85.5	0.32	1	13.3	

## COOKIE swivel

5007-4STP

Design Studio Zetass

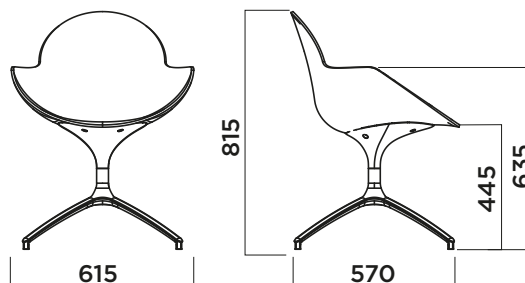

<p><b>BASE</b> BASE BASE</p>	<p>Painted aluminium base and support with epoxy-polyester powder with average thickness of 50 <math>\mu</math>. Polished die cast aluminium. Base e supporto in alluminio verniciato a polveri epossipoliesteri spessore medio di 50 <math>\mu</math>. Alluminio pressofuso lucido. Base y soporte de aluminio con recubrimiento en polvo epoxipoliéster con 50 <math>\mu</math> de espesor medio. Aluminio fundido a presión pulido</p>
<p><b>SHELL</b> SCOCCA CARCASA</p>	<p>Polypropylene + Glass fiber Polipropilene + Fibra di vetro Polipropileno + Fibra de vidrio</p>
<p><b>FEET</b> PIEDINI PIES DE APOYO</p>	<p>Polypropylene Polipropilene Polipropileno</p>
<p><b>OTHER PLASTICS</b> ALTRE PLASTICHE OTROS PLÁSTICOS</p>	<p>Polypropylene. Polipropilene Polipropileno</p>

Pkg	A(cm)	B(cm)	h(cm)	MC	PCS	Weight (kg)
59	63	85.5	0.32	1	14.7	





Reproduction of this document is strictly prohibited without prior written authorisation from Omp srl. Sizes, weights and finishes may change without previous notice.  
 È vietata la riproduzione del seguente documento senza previa autorizzazione scritta da parte di Omp srl. Dimensioni, pesi e finiture possono variare senza alcun preavviso.  
 La reproducción de este documento está estrictamente prohibida sin la autorización previa de Omp srl. Los tamaños, pesos y acabados pueden cambiar sin previo aviso.

## COOKIE swivel upholstered

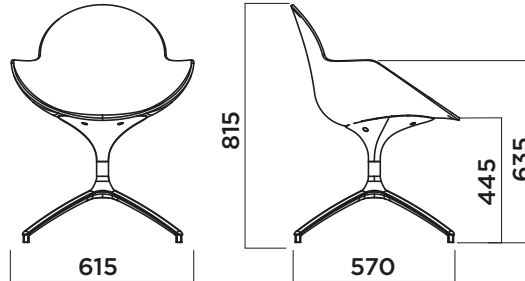
5007-4STT

Design Studio Zetass



<p><b>BASE</b> BASE BASE</p>	<p>Painted aluminium base and support with epoxy-polyester powder with average thickness of 50 <math>\mu</math>. Polished die cast aluminium. Base e supporto in alluminio verniciato a polveri epossipoliesteri spessore medio di 50 <math>\mu</math>. Alluminio pressofuso lucido. Base y soporte de aluminio con recubrimiento en polvo epoxi-poliéster con 50 <math>\mu</math> de espesor medio. Aluminio fundido a presión pulido</p> <div style="display: flex; justify-content: space-around; align-items: center;"> <div style="text-align: center;">  <b>00L</b> </div> <div style="text-align: center;">  <b>30</b> </div> <div style="text-align: center;">  <b>31</b> </div> </div>														
<p><b>UPHOLSTERY</b> TAPPEZZERIA TAPIZADOS</p>	<p>Upholstered shell Scocca tappezzata Upholstered shell</p> <ul style="list-style-type: none"> <li><b>A</b> Space, Panarea</li> <li><b>B</b> Eco Leather</li> <li><b>C</b> Convert D, Velvety, Step, Step Melange, Nuvole</li> <li><b>D</b> Reflect </li> <li><b>E</b> Oceanic  Yoredale</li> <li><b>F</b> Canvas2</li> <li><b>G</b> Fiord, Patio</li> </ul> <table style="width: 100%; border-collapse: collapse;"> <tr> <td style="text-align: center;"><b>COM Fabric(m)</b></td> <td style="text-align: center;"><b>COM Leather(m2)</b></td> </tr> <tr> <td style="text-align: center;">1,10</td> <td style="text-align: center;">1,70</td> </tr> </table>	<b>COM Fabric(m)</b>	<b>COM Leather(m2)</b>	1,10	1,70										
<b>COM Fabric(m)</b>	<b>COM Leather(m2)</b>														
1,10	1,70														
<p><b>FEET</b> PIEDINI PIES DE APOYO</p>	<p>Polypropylene Polipropilene Polipropileno</p>														
<p><b>OTHER PLASTICS</b> ALTRE PLASTICHE OTROS PLÁSTICOS</p>	<p>Polypropylene Polipropilene Polipropileno</p>														
<p><b>PKG</b> IMBALLO EMBALAJE</p>	<table border="1" style="width: 100%; border-collapse: collapse;"> <thead> <tr> <th>Pkg</th> <th>A(cm)</th> <th>B(cm)</th> <th>h(cm)</th> <th>MC</th> <th>PCS</th> <th>Weight (kg)</th> </tr> </thead> <tbody> <tr> <td style="text-align: center;">59</td> <td style="text-align: center;">63</td> <td style="text-align: center;">85.5</td> <td style="text-align: center;">0.32</td> <td style="text-align: center;">1</td> <td style="text-align: center;">14.7</td> <td></td> </tr> </tbody> </table>	Pkg	A(cm)	B(cm)	h(cm)	MC	PCS	Weight (kg)	59	63	85.5	0.32	1	14.7	
Pkg	A(cm)	B(cm)	h(cm)	MC	PCS	Weight (kg)									
59	63	85.5	0.32	1	14.7										

Reproduction of this document is strictly prohibited without prior written authorisation from Omp srl. Sizes, weights and finishes may change without previous notice.  
 È vietata la riproduzione del seguente documento senza previa autorizzazione scritta da parte di Omp srl. Dimensioni, pesi e finiture possono variare senza alcun preavviso.  
 La reproducción de este documento está estrictamente prohibida sin la autorización previa de Omp srl. Los tamaños, pesos y acabados pueden cambiar sin previo aviso.

## COOKIE swivel with castors

5007-4SCP

Design Studio Zetass

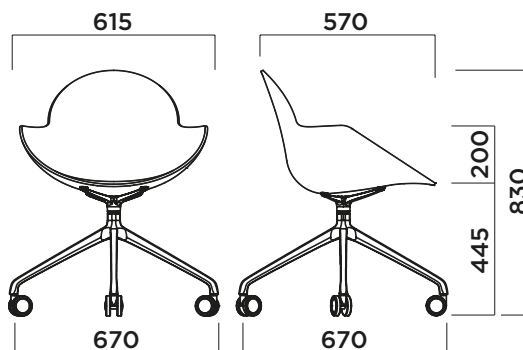

<p><b>BASE</b> BASE BASE</p>	<p>Painted aluminium base and support with epoxy-polyester powder with average thickness of 50 <math>\mu</math>. Polished die cast aluminium. Base e supporto in alluminio verniciato a polveri epossipoliesteri spessore medio di 50 <math>\mu</math>. Alluminio pressofuso lucido. Base y soporte de aluminio con recubrimiento en polvo epoxi-poliéster con 50 <math>\mu</math> de espesor medio. Aluminio fundido a presión pulido</p>
<p><b>SHELL</b> SCocca CARCASA</p>	<p>Polypropylene + Glass fiber Polipropilene + Fibra di vetro Polipropileno + Fibra de vidrio</p>
<p><b>CASTORS</b> RUOTE RUEDAS PIVOTANTES</p>	<p>Castors diam. 60 stem 11. Ruote diam. 60 stem 11. Ruedas pivotantes diám. 60 perno 11.</p>
<p><b>OTHER PLASTICS</b> ALTRE PLASTICHE OTROS PLÁSTICOS</p>	<p>Polypropylene. Polipropilene Polipropileno</p>



Pkg	A(cm)	B(cm)	h(cm)	MC	PCS	Weight (kg)
59	63	85.5	0.32	1	14.7	

Reproduction of this document is strictly prohibited without prior written authorisation from Omp srl. Sizes, weights and finishes may change without previous notice.  
 È vietata la riproduzione del seguente documento senza previa autorizzazione scritta da parte di Omp srl. Dimensioni, pesi e finiture possono variare senza alcun preavviso.  
 La reproducción de este documento está estrictamente prohibida sin la autorización previa de Omp srl. Los tamaños, pesos y acabados pueden cambiar sin previo aviso.

## COOKIE swivel with castors upholstered

5007-4SCT

Design Studio Zetass

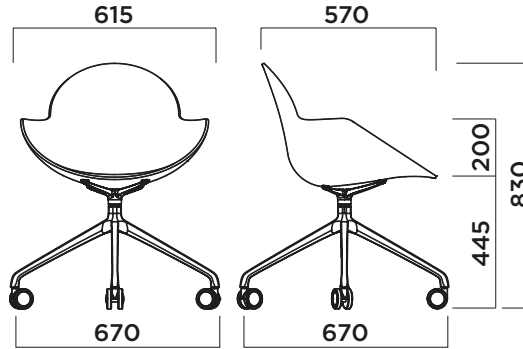

### BASE

BASE

BASE

Painted aluminium base and support with epoxy-polyester powder with average thickness of 50  $\mu$ . Polished die cast aluminium.

Base e supporto in alluminio verniciato a polveri epossipoliesteri spessore medio di 50  $\mu$ . Alluminio pressofuso lucido.

Base y soporte de aluminio con recubrimiento en polvo epoxi-poliéster con 50  $\mu$  de espesor medio. Aluminio fundido a presión pulido



00L



30



31

### UPHOLSTERY

TAPPEZZERIA

TAPIZADOS

Upholstered shell

Scocca tappezzata

Upholstered shell

- A Space, Panarea
- B Eco Leather
- C Convert D, Velvety, Step, Step Melange, Nuvole
- D Reflect
- E Oceanic , Yoredale
- F Canvas2
- G Fiord, Patio

COM Fabric(m)    COM Leather(m2)

1.10

1.70

### CASTORS

RUOTE

RUEDAS PIVOTANTES

Castors diam. 60 stem 11.

Ruote diam. 60 stem 11.

Ruedas pivotantes diám. 60 perno 11.

### OTHER PLASTICS

ALTRE PLASTICHE

OTROS PLÁSTICOS

Polypropylene.

Polipropilene

Polipropileno

### PKG

IMBALLO

EMBALAJE

Pkg	A(cm)	B(cm)	h(cm)	MC	PCS	Weight (kg)
59	63	85.5	0.32	1	14.7	

## COOKIE 5 stars updown

5007-5SUP

Design Studio Zetass

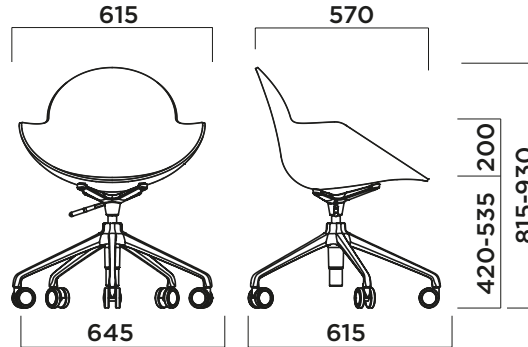

<p><b>BASE</b> BASE BASE</p>	<p>Painted aluminium base and support with epoxy-polyester powder with average thickness of 50 <math>\mu</math>. Polished die cast aluminium. Base e supporto in alluminio verniciato a polveri epossipoliesteri spessore medio di 50 <math>\mu</math>. Alluminio pressofuso lucido. Base y soporte de aluminio con recubrimiento en polvo eposi-poliéster con 50 <math>\mu</math> de espesor medio. Aluminio fundido a presión pulido</p>
<p><b>SHELL</b> SCocca CARCASA</p>	<p>Polypropylene + Glass fiber Polipropilene + Fibra di vetro Polipropileno + Fibra de vidrio</p>
<p><b>CASTORS</b> RUOTE RUEDAS PIVOTANTES</p>	<p>Castors diam. 60 stem 11. Ruote diam. 60 stem 11. Ruedas pivotantes diám. 60 perno 11.</p>
<p><b>GAS COLUMN</b> COLONNA A GAS PISTÓN DE GAS</p>	<p>Gas column <math>\varnothing</math> 50. Colonna a gas <math>\varnothing</math> 50. Pistón de gas <math>\varnothing</math> 50.</p>
<p><b>OTHER PLASTICS</b> ALTRE PLASTICHE OTROS PLÁSTICOS</p>	<p>Polypropylene Polipropilene Polipropileno</p>



Pkg	A(cm)	B(cm)	h(cm)	MC	PCS	Weight (kg)
IMBALLO EMBALAJE	59	63	85.5	0.32	1	14.7





Reproduction of this document is strictly prohibited without prior written authorisation from Omp srl. Sizes, weights and finishes may change without previous notice.  
 È vietata la riproduzione del seguente documento senza previa autorizzazione scritta da parte di Omp srl. Dimensioni, pesi e finiture possono variare senza alcun preavviso.  
 La reproducción de este documento está estrictamente prohibida sin la autorización previa de Omp srl. Los tamaños, pesos y acabados pueden cambiar sin previo aviso.

## COOKIE 5 stars updown upholstered

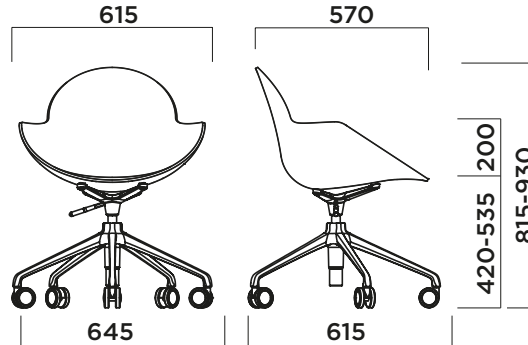
5007-5SUT

Design Studio Zetass



<p><b>BASE</b> BASE BASE</p>	<p>Painted aluminium base and support with epoxy-polyester powder with average thickness of 50 <math>\mu</math>. Polished die cast aluminium. Base e supporto in alluminio verniciato a polveri epossipoliesteri spessore medio di 50 <math>\mu</math>. Alluminio pressofuso lucido. Base y soporte de aluminio con recubrimiento en polvo epoxi-poliéster con 50 <math>\mu</math> de espesor medio. Aluminio fundido a presión pulido</p> <div style="display: flex; justify-content: space-around; align-items: center;"> <div style="text-align: center;">  <b>00L</b> </div> <div style="text-align: center;">  <b>30</b> </div> <div style="text-align: center;">  <b>31</b> </div> </div>
<p><b>UPHOLSTERY</b> TAPPEZZERIA TAPIZADOS</p>	<p>Upholstered shell Scocca tappezzata Upholstered shell</p> <p><b>A</b> Space,Panarea <b>B</b> Eco Leather <b>C</b> Convert D,Velvety,Step, Step Melange, Nuvole <b>D</b> Reflect  <b>E</b> Oceanic , Yoredale <b>F</b> Canvas2 <b>G</b> Fiord,Patio</p> <p><b>COM Fabric(m)</b>    <b>COM Leather(m2)</b></p> <p style="text-align: center;"><b>1,10</b>                      <b>1,70</b></p>
<p><b>CASTORS</b> RUOTE RUEDAS PIVOTANTES</p>	<p>Castors diam. 60 stem 11. Ruote diam. 60 stem 11. Ruedas pivotantes diám. 60 perno 11.</p>
<p><b>GAS COLUMN</b> COLONNA A GAS PISTÓN DE GAS</p>	<p>Gas column <math>\varnothing</math> 50. Colonna a gas <math>\varnothing</math> 50. Pistón de gas <math>\varnothing</math> 50.</p>
<p><b>OTHER PLASTICS</b> ALTRE PLASTICHE OTROS PLÁSTICOS</p>	<p>Polypropylene Polipropilene Polipropileno</p>

Pkg	A(cm)	B(cm)	h(cm)	MC	PCS	Weight (kg)
	59	63	85.5	0.32	1	14.7

Reproduction of this document is strictly prohibited without prior written authorisation from Omp srl. Sizes, weights and finishes may change without previous notice.  
 È vietata la riproduzione del seguente documento senza previa autorizzazione scritta da parte di Omp srl. Dimensioni, pesi e finiture possono variare senza alcun preavviso.  
 La reproducción de este documento está estrictamente prohibida sin la autorización previa de Omp srl. Los tamaños, pesos y acabados pueden cambiar sin previo aviso.