



vivax

IRODABÚTOR

true

INDEX

FEATURES

TECNICO

p.234 Technical Drawings
p.254 Designers

ACOUSTIC

ACUSTICI

p.34 Oracle
p.192 Pincettes

ARMCHAIRS

POLTRONE

p.34 Oracle
p.132 Nosmoking
p.60 Not
p.70 Arca
p.84 Clara
p.94 Hive
p.102 Slight
p.112 Wrap
p.124 Biblis
p.140 Poseidone
p.146 Aladdin
p.154 Hebe

COLORS

COLORI

p.8 Colors

TABLES

TAVOLI

p.210 Wing
p.228 Zero
p.229 Oracle
p.230 Millepiedi
p.231 Wrap

CHAIRS

SEDIE

p.94 Hive
p.162 Marina
p.172 Kay
p.178 Gea
p.184 Grillo

SOFAS

DIVANI

p.34 Oracle
p.132 Nosmoking
p.84 Clara
p.94 Hive
p.102 Slight
p.112 Wrap
p.124 Biblis
p.140 Poseidone
p.146 Aladdin
p.154 Hebe

SYSTEMS

SISTEMI

p.16 Millepiedi
p.34 Oracle
p.46 Dna

A-Z

p.146 Aladdin
p.70 Arca
p.124 Biblis
p.84 Clara
p.46 Dna
p.178 Gea
p.184 Grillo
p.154 Hebe
p.94 Hive
p.172 Kay
p.162 Marina
p.16 Millepiedi
p.132 Nosmoking
p.60 Not
p.34 Oracle
p.192 Pincettes
p.140 Poseidone
p.102 Slight
p.210 Wing
p.112 Wrap
p.228 Zero

COLORS

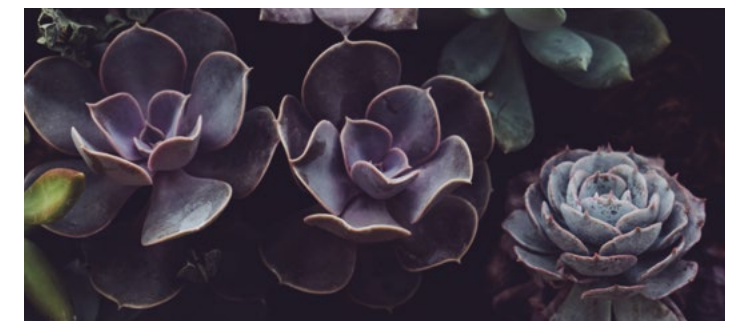
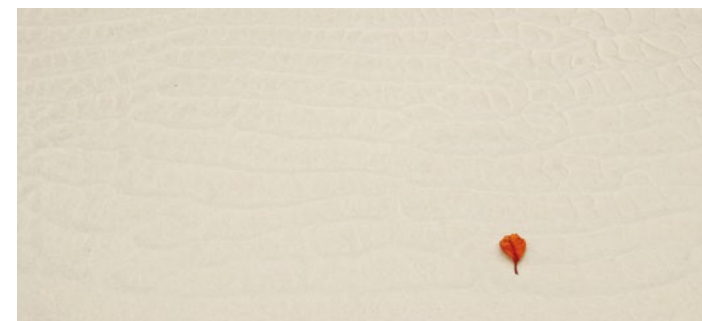
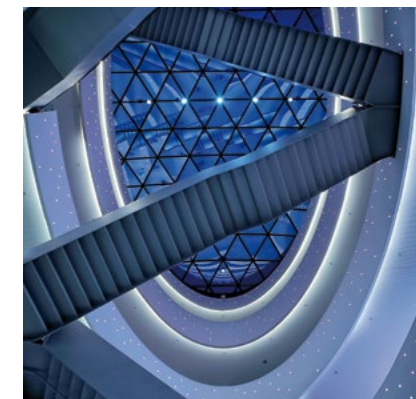
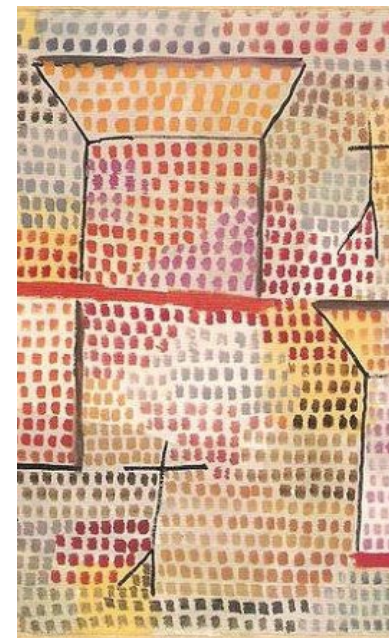
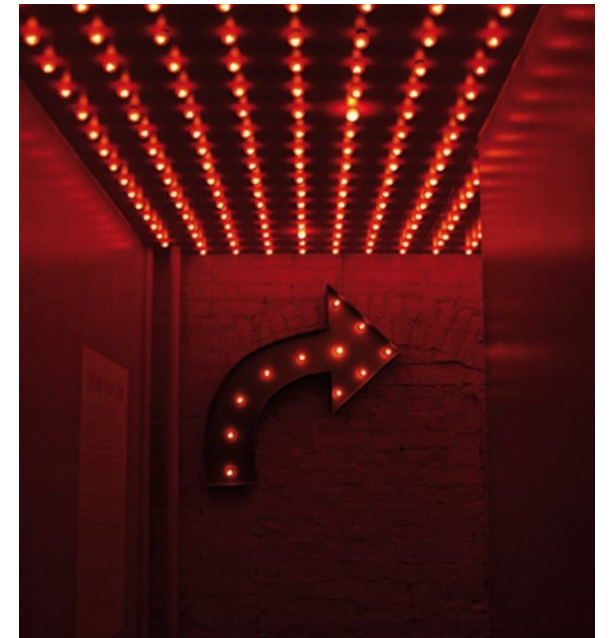
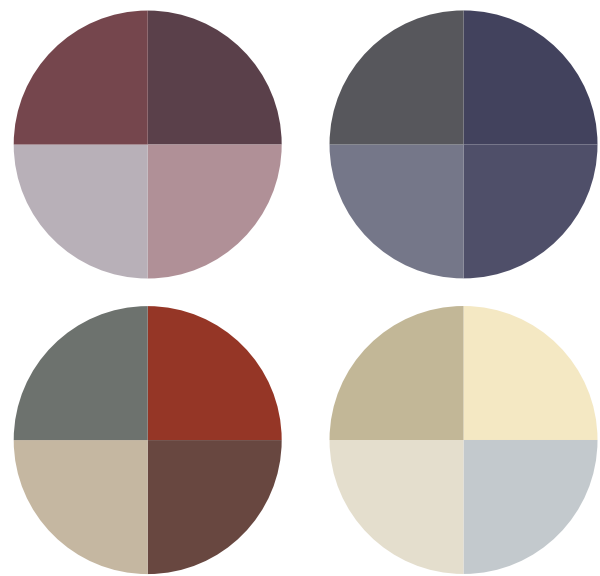

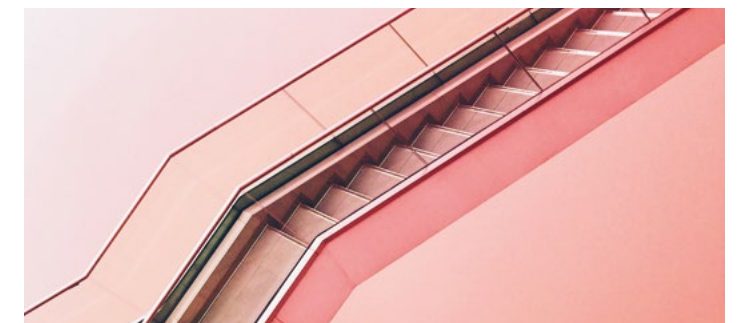
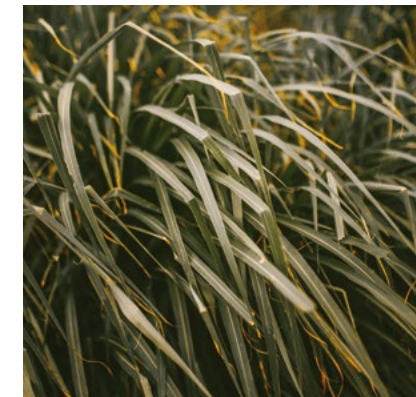
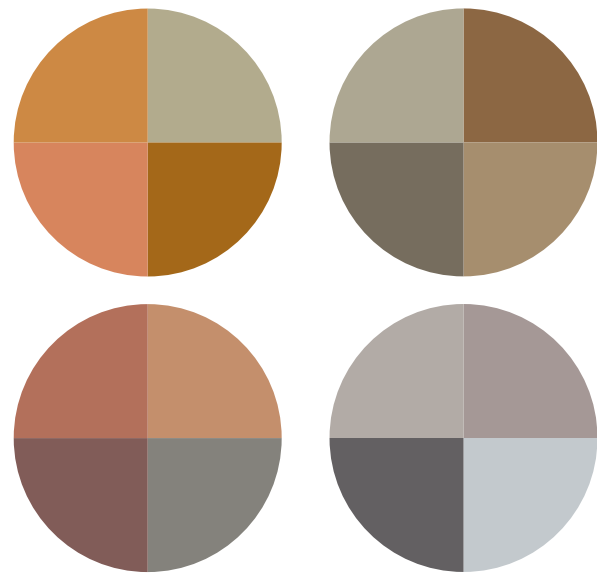

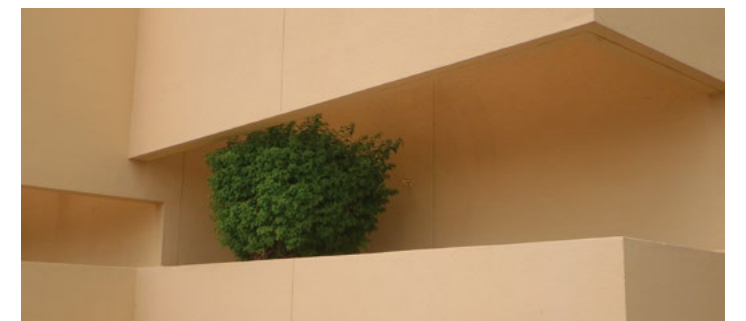
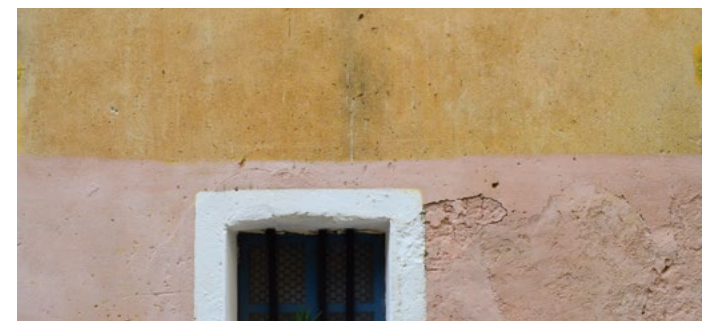
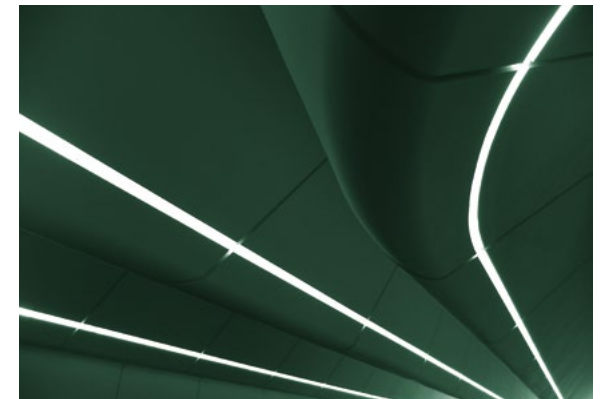
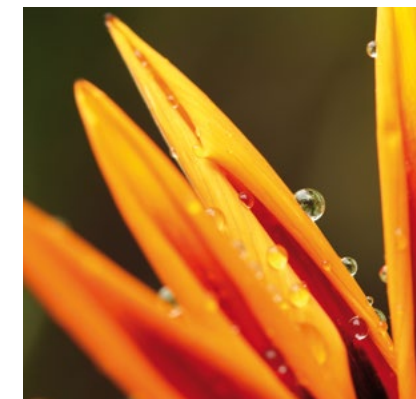
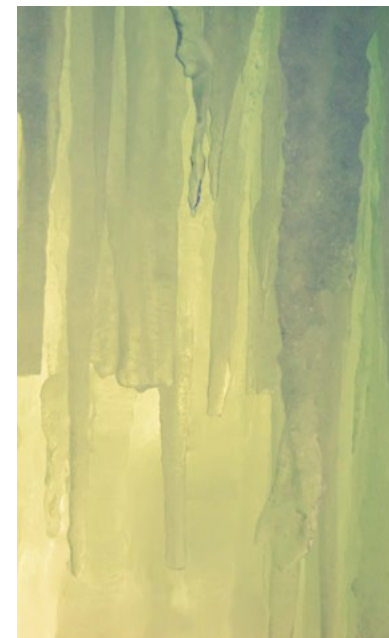
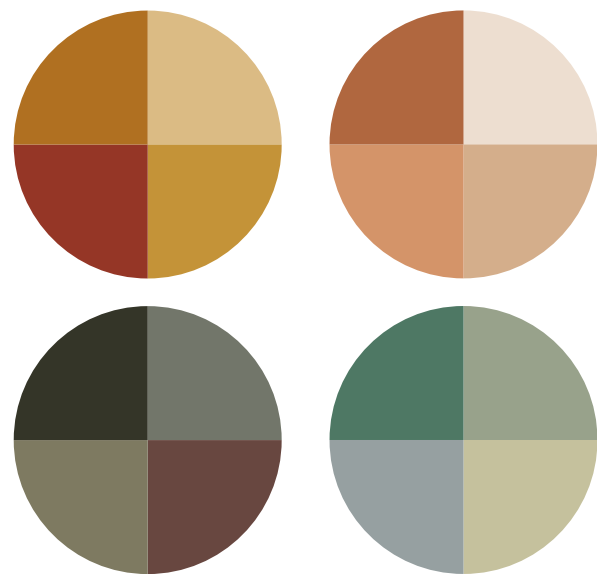

COLLECTION

MILLEPIEDI

P+F Parisotto+Formenton

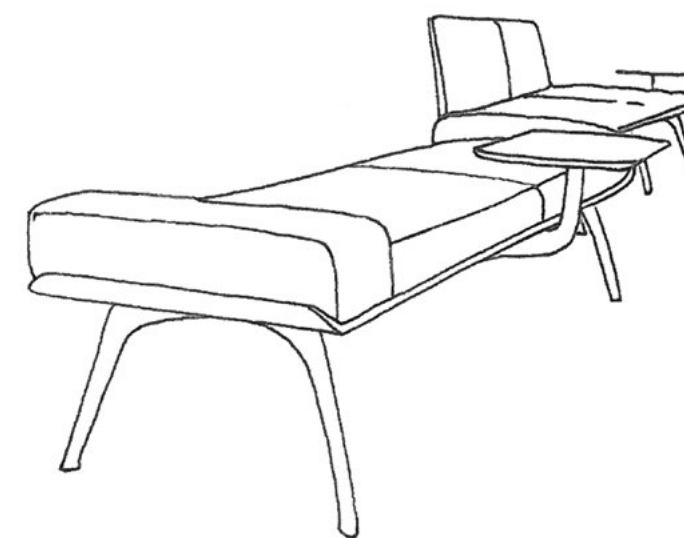

Il design contemporaneo ed essenziale del sistema di sedute Millepiedi declina in molte configurazioni e dimensioni un'idea concettuale di funzionalità e flessibilità coniugata con un'estetica fatta di dettagli curatissimi.

Millepiedi è stato inserito nel prestigioso ADI Design Index, la pubblicazione annuale di ADI Associazione per il Disegno Industriale che raccoglie il miglior design italiano messo in produzione, selezionato dall'Osservatorio permanente del Design ADI.

The Millepiedi seating system is characterized by a modern and minimal design and develops a concept of functionality and flexibility in a wide range of configurations and dimensions.

Millepiedi has been included in the prestigious ADI Design Index book, an annual publication by the Association for the Industrial Design, which collects the best pieces of Italian design selected by the Permanent Observatory of Design ADI.





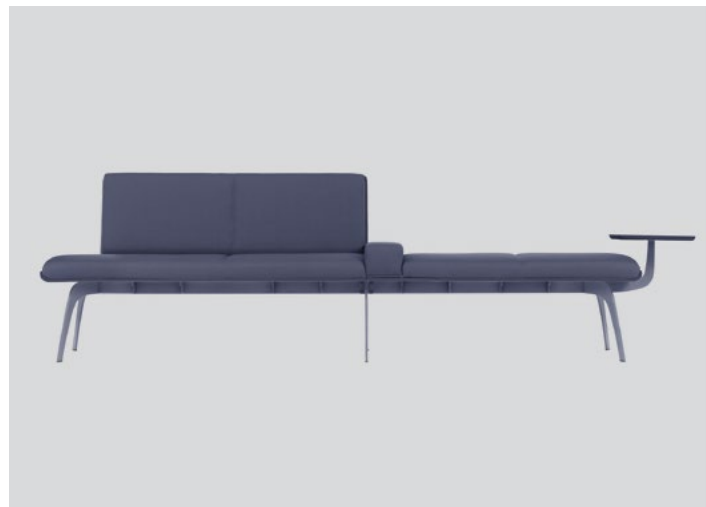
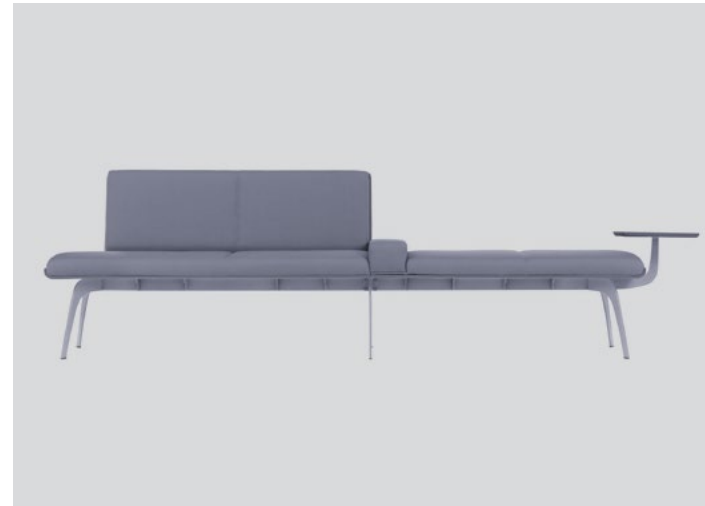
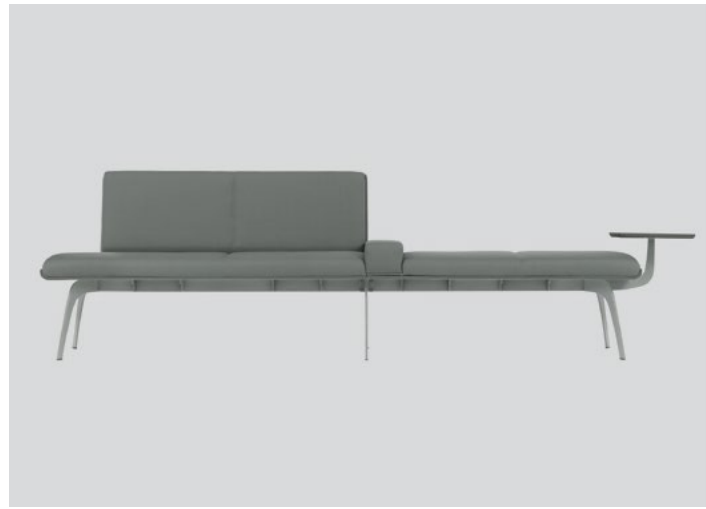







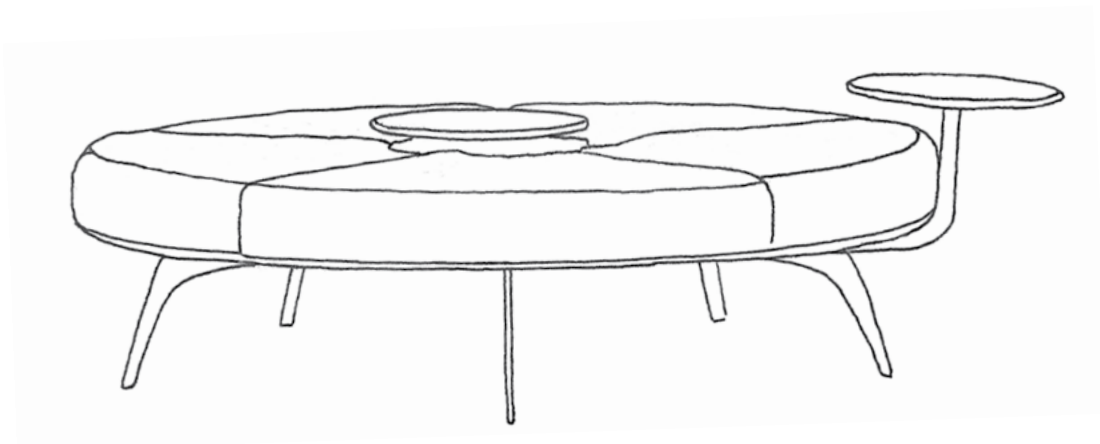

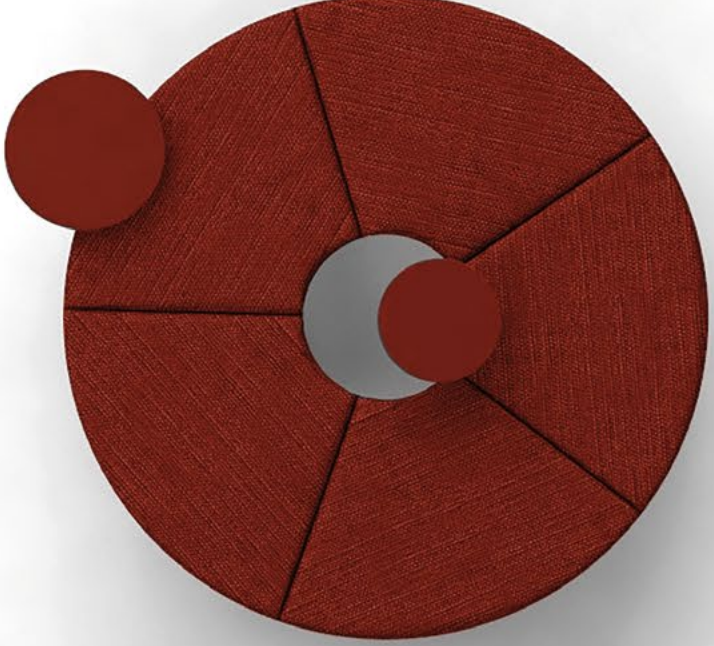
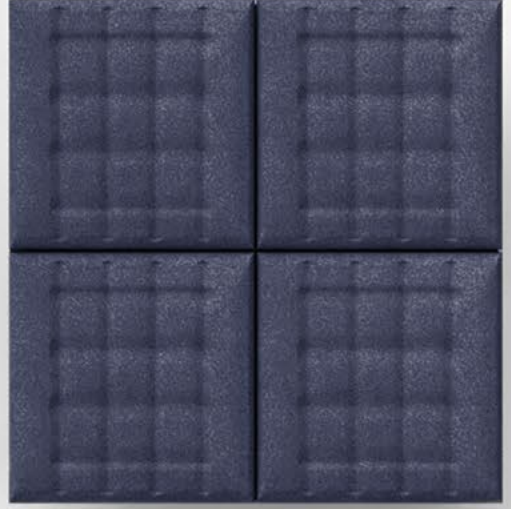

ORACLE

Orlandini Design

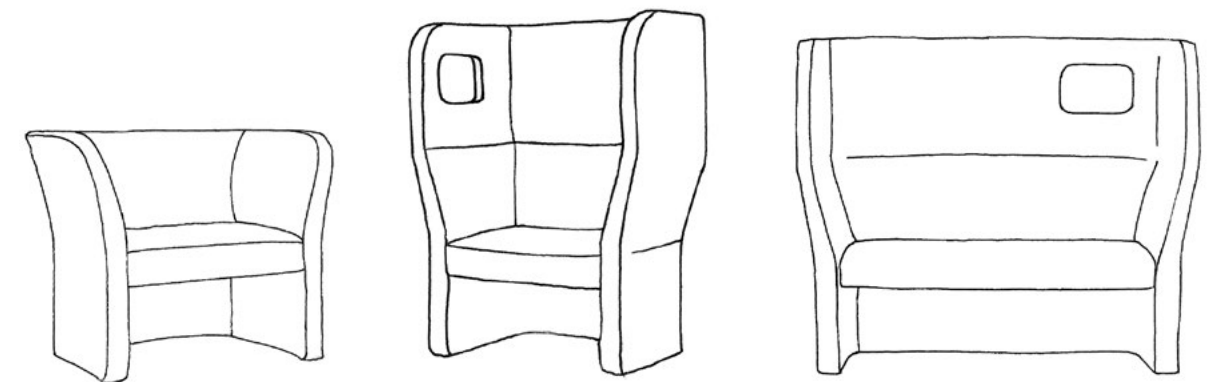

Sistema componibile di sedute imbottite per aree pubbliche caratterizzate dallo schienale molto alto e protettivo della privacy, una sorta di muro divisorio con il mondo esterno. Più che semplici divani sono dei veri e propri mini-ambienti in cui poter ritrovare la giusta dimensione per lavorare, discutere o anche solo riposare.

La nuova gamma Oracle prevede una collezione di scrivanie e banchi installati sulla stessa struttura imbottita di Oracle con schienale alto. I tavoli possono essere usati come postazione lavoro veloce in spazi aperti e consentono la creazione di microambienti ufficio combinati con gli elementi divano e paretina. I piani in legno o MDF laccato possono essere elettrificati con prese e USB.

Modular system of upholstered seats for public areas, characterized by the high and embracing backrest that gives a great privacy protection, working as a divider from the outside world. Oracle are something more than just sofas, they are actually mini-environments where to find the right dimension you need for working, having a chat or simply relaxing. The new collection of Oracle includes a range of desks and counters installed on the same upholstered high backrest structure of the sofa. These new elements can be used as a flexible workstation in open areas, allowing to create "micro-office" spaces when combined with the Oracle sofa and connection wall. Desk tops, available in wood or lacquered MDF, can be integrated with power and USB outputs.





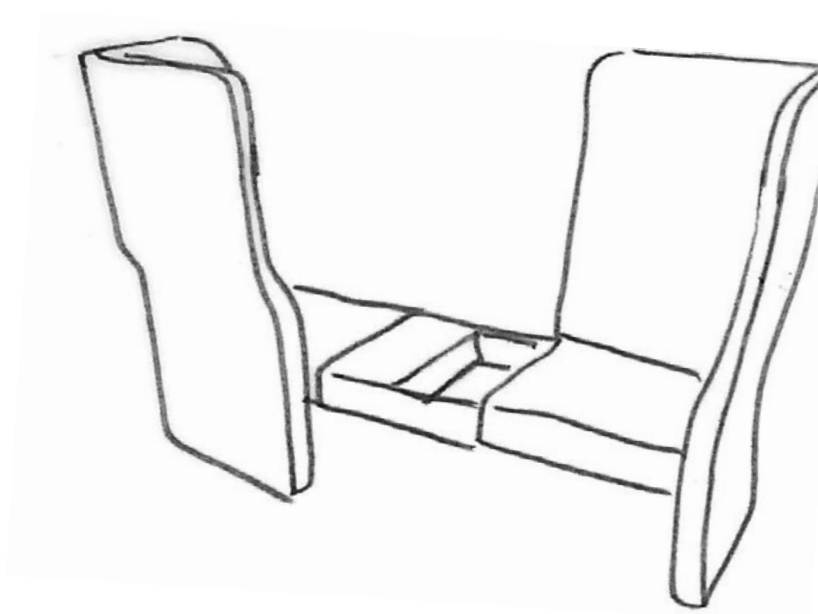

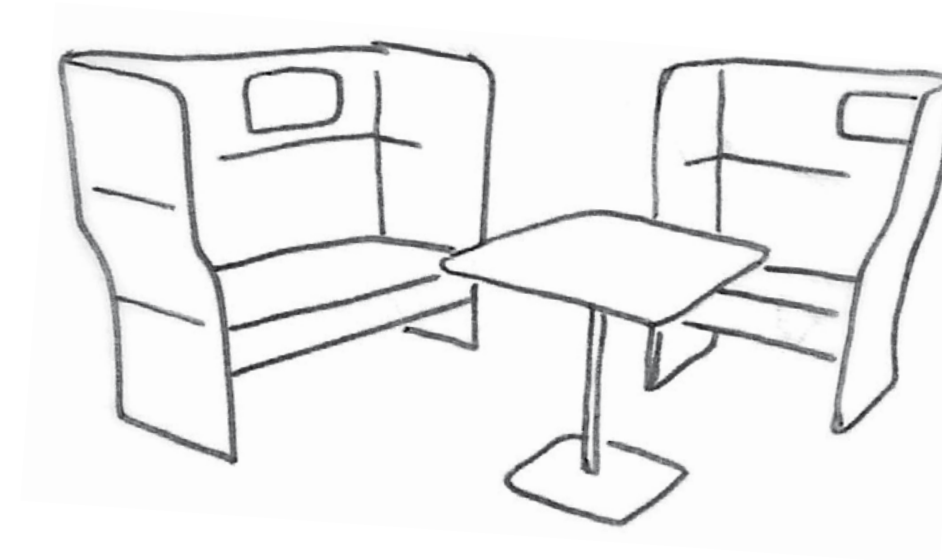



DNA

Leonardo Rossano & Debora Mansur

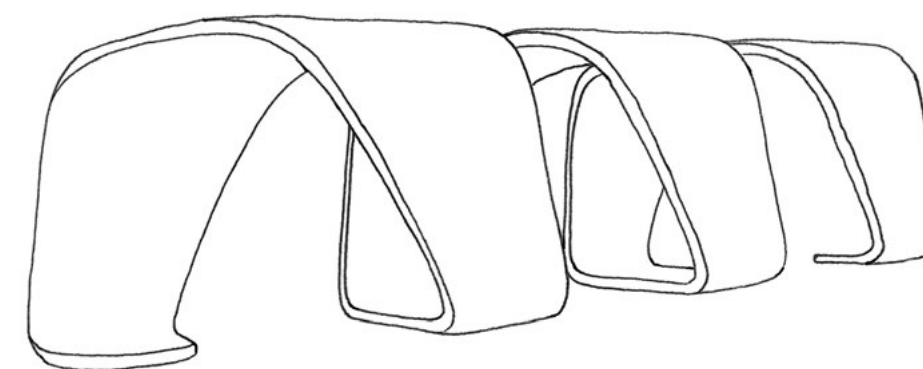

Ispirata dalle forme dinamiche della biogenetica, la panca modulare DNA consiste in un singolo elemento in multistrato di legno curvato, assemblato specularmente. Il risultato è un avvolgente elemento d'arredo dalla particolare forma ad elica, ad ogni passo della quale corrisponde una seduta opportunamente separata dalle altre. La struttura in legno può essere completamente a vista o rivestita nella sua parte anteriore.

La nuova versione a elementi curvi permette di creare composizioni originali, ad arco o a "S".

Inspired by the dynamic forms of biogenetics, the modular bench DNA consists in a unique construction assembly that is created by a single section of curved plywood, which is mirrored in design to create multiple seating configurations. The result of this system is a captivating piece of furniture, shaped after the helix form in which each completed section creates an individual seat for the user creating comfort in a public space. The wooden structure can also be upholstered on its front side. The new version of DNA with curved elements allows to create original composition, arch or "S" shaped.



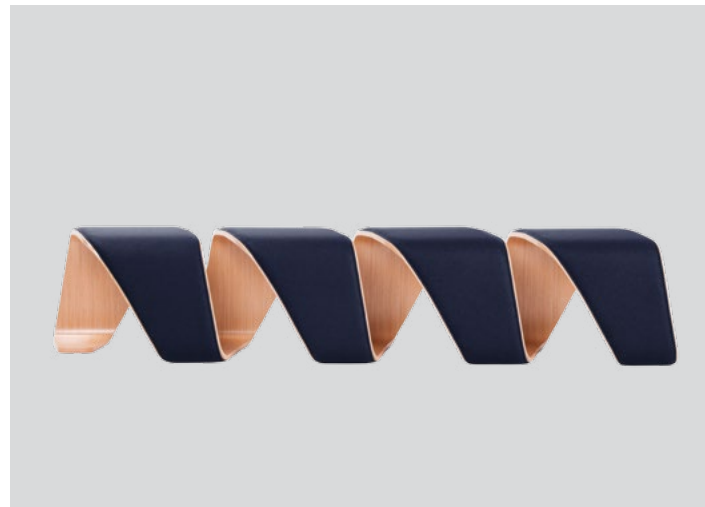
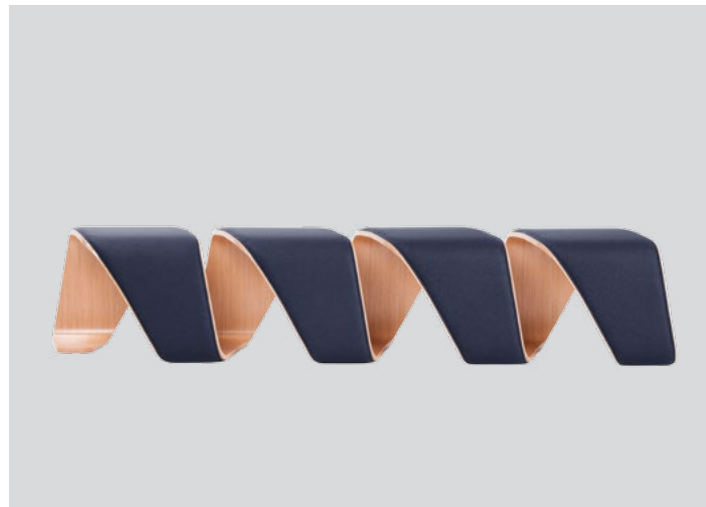
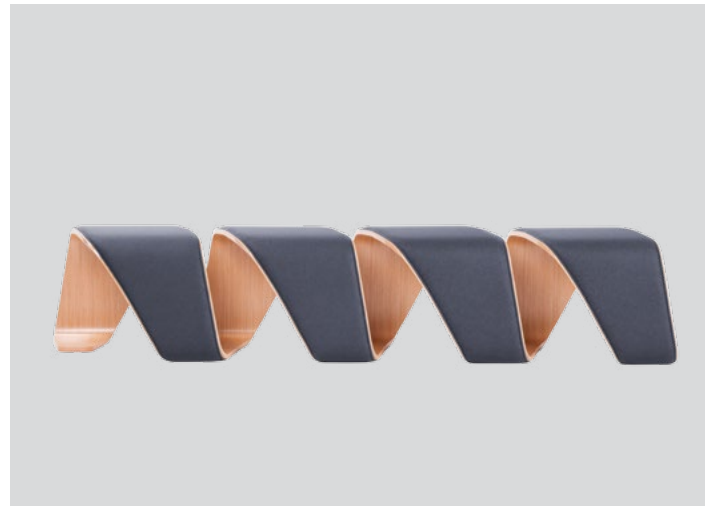
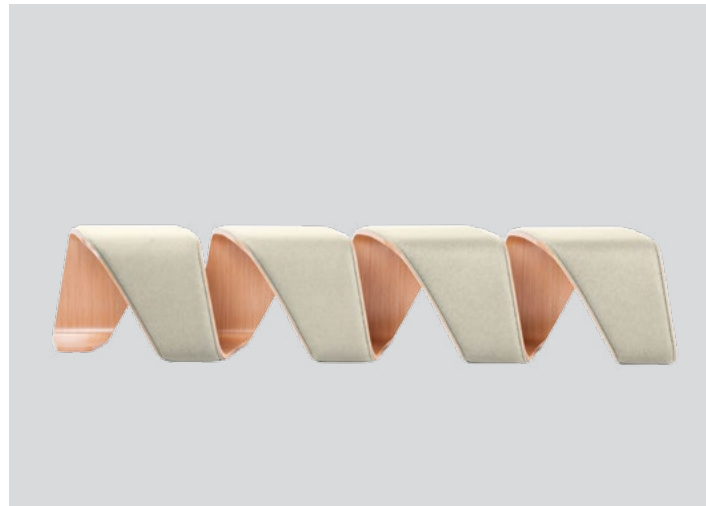
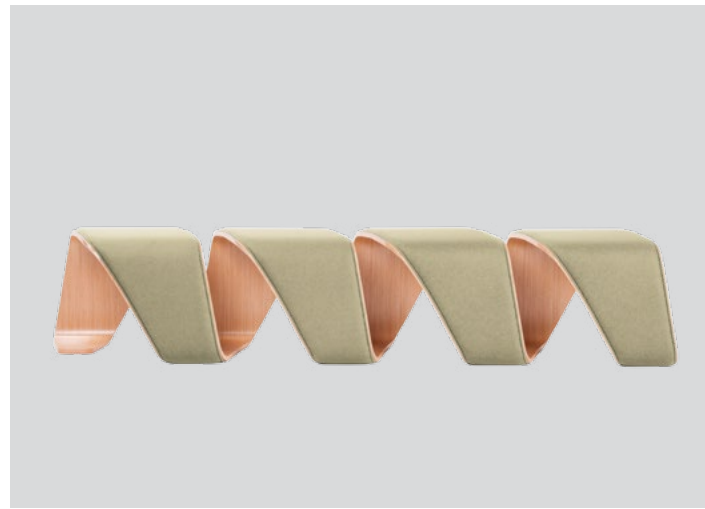
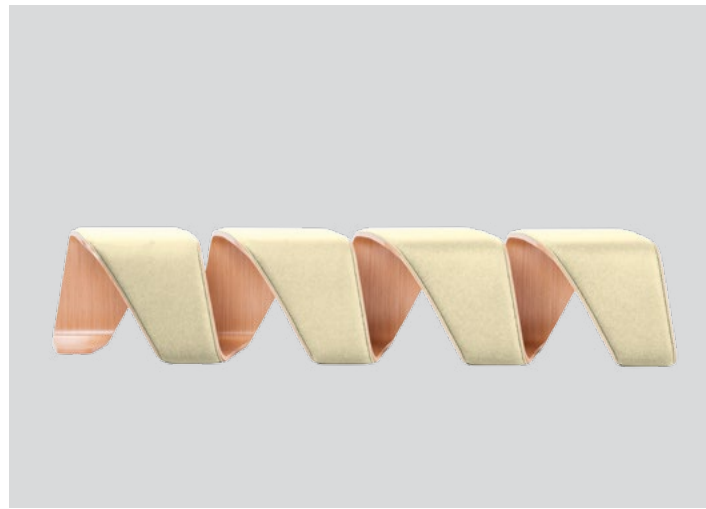

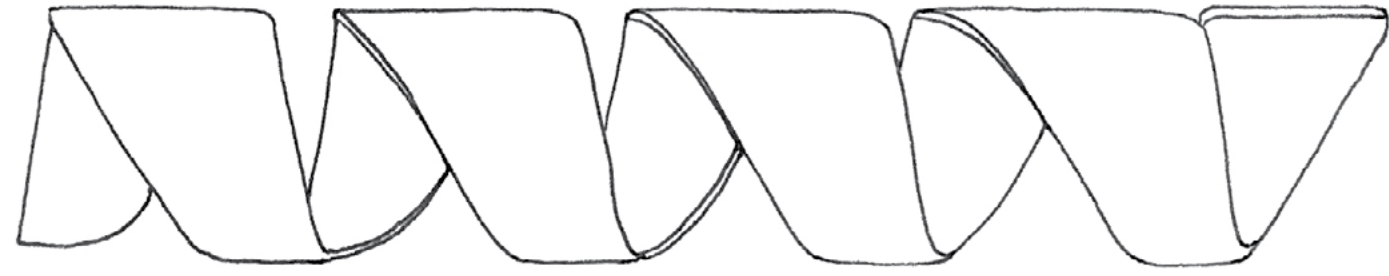



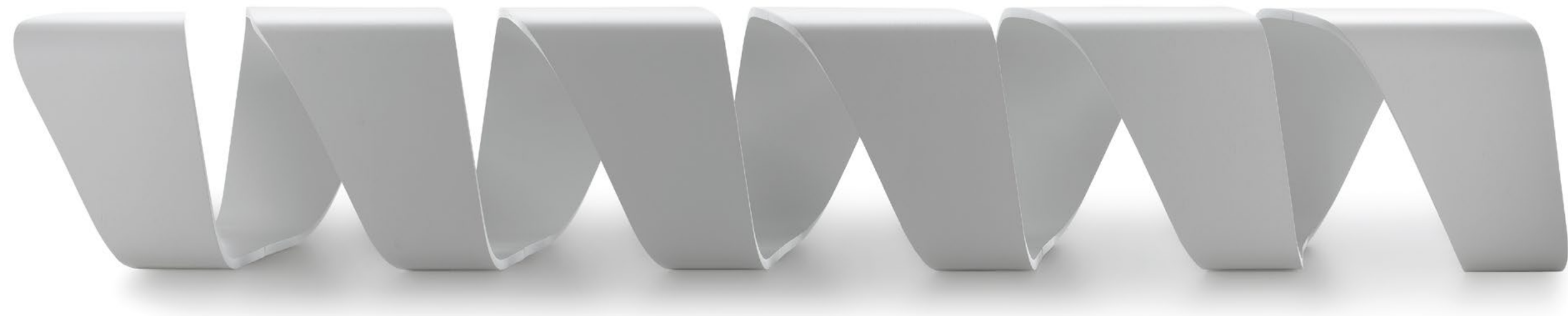





NOT

E-ggs Design

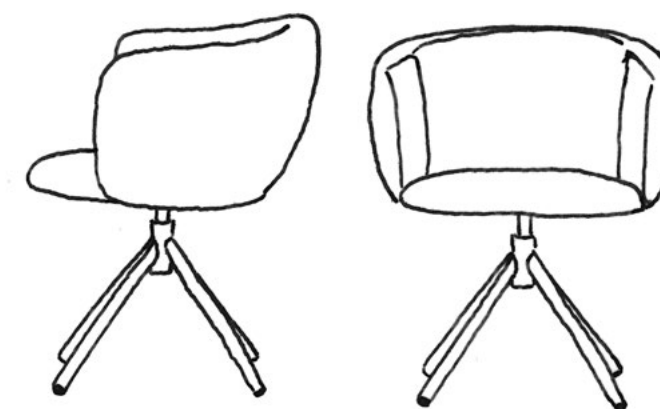

Un'ampia scocca avvolgente racchiude la seduta in un morbido abbraccio. Le cuciture ne definiscono e disegnano le linee morbide, dandole un aspetto elegante e versatile. Adatta a sale conferenza e aree relax di hotel e residenze.

A wide shell embraces the seat in a warm embrace. The seams define the soft lines, giving it an elegant and versatile look. Suitable for conference hall and relax spaces of hotel and domestic environment.







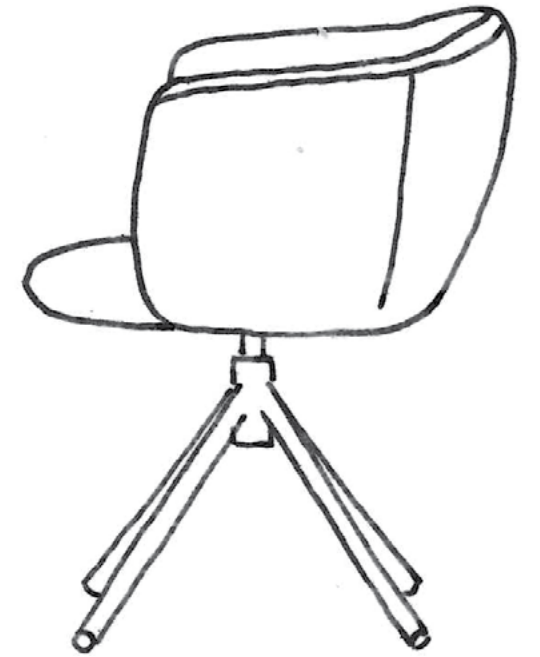

ARCA

Orlandini Design



Arca rappresenta una declinazione completa del concetto di poltrona per spazi attesa, meeting e lounge, proponendosi in 2 dimensioni di seduta e 3 differenti altezze di schienale abbinabili a numerose tipologie di basamenti. La versione "lounge" con schienale basso è ideale per ambienti attesa veloci, o per grandi meeting rooms, mentre la variante con schienalino aggiunto dona maggiore importanza e comfort alla seduta. La sua declinazione più caratterizzante è con lo schienale alto, avvolgente, ma non invadente, per una pausa in completo relax, anche nella particolare configurazione con base a dondolo. Arca "small" ripropone le forme della versione "lounge" ridimensionate per zone riunione. Arca ricalca alla perfezione l'attuale concetto di "Smart Lounge", in cui l'attesa diventa un momento di riflessione, lavoro o semplice relax sul web; tutte le versioni di Arca sono pertanto accessoriabili con una tavoletta di appoggio, dalle dimensioni generose, installata su un meccanismo di rotazione.

Arca defines a new concept of armchair for lounges and waiting areas, available in 3 backrest heights, which can be combined to many base typologies. The Lounge version, with low backrest, is ideal for quick waiting areas, large meeting rooms, while the medium back option, with backrest cushion, gives more prestige and comfort to the armchair. The High version gives the unique touch of design to this collection, with its embracing backrest for a break of full relax, especially with its rocking base. Arca "small" keeps the same design of the "lounge" version, resized for meeting environments.

Arca perfectly traces the new concept of "Smart Lounge", where waiting moments become great occasions for reflection, working or relaxing on the web; all versions of Arca can indeed be equipped with a large writing tablet, swivel around the arm.















CLARA

P+F Parisotto+Formenton

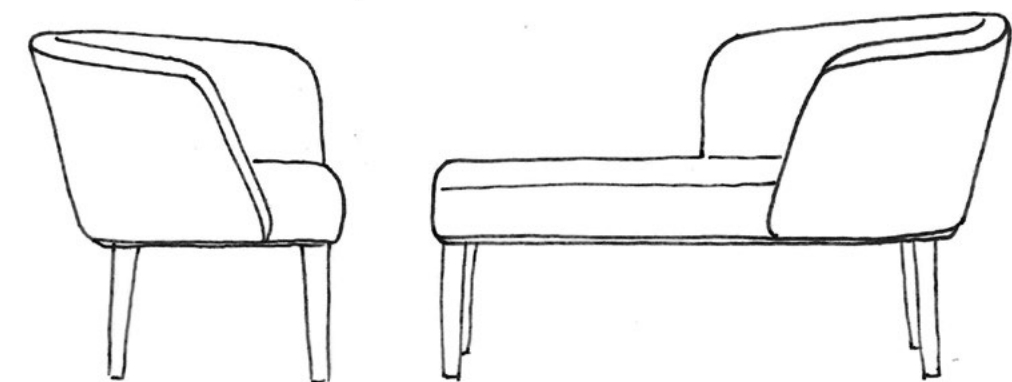

Piccola collezione di sedute, composta da poltroncina e dormeuse, caratterizzata da forme avvolgenti.

Clara abbraccia la persona seduta grazie ad un accogliente elemento che serve da schienale e bracciolo. La sua marcata asimmetria emerge come la maggiore connotazione estetica di un arredo di ispirazione classica, ma di taglio contemporaneo, che vuole evidenziare al primo sguardo l'invito ad una seduta confortevole, rilassata ed informale tra le sue curve.

Collection of seats composed by armchair and dormeuse, defined by sinuous shapes.

Clara embraces the person seated thanks to a comfortable element working as backrest and armrest. Its pronounced asymmetry emerges as the main aesthetic feature in this piece of furniture of classic inspiration but of modern design. A comfortable seat, relaxing and informal alongside its rounded shapes.











HIVE

Favaretto & Partners

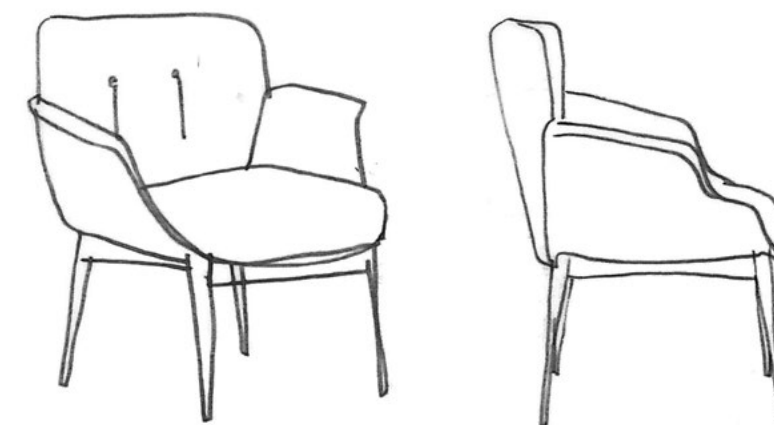

Hive rappresenta la sintesi della poltrona nello spazio direzionale, proponendo una collezione completa di sedute girevoli per ufficio e poltrone per tavoli riunioni e ambienti d'attesa caratterizzate dalla struttura in legno massello. Le forme rigorose sono armonizzate dalle cuciture che ne valorizzano il design.

Hive represents the synthesis of the armchair in the executive environment, with a full collection of rotating chairs for the office and solid wood armchairs for meeting tables or waiting areas. The rigorous shapes get along with the stitching, endorsing the design.







SLIGHT

Christophe Bourban & Luciano Dell'Orefice

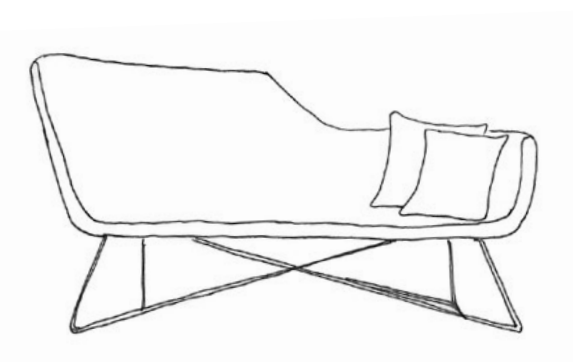
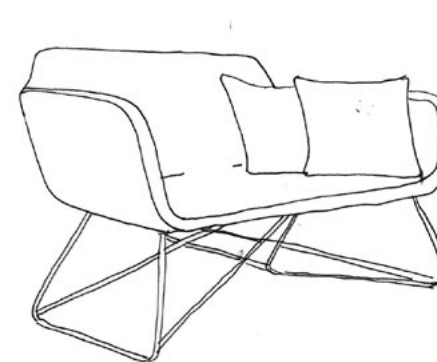

Sottile come una foglia, la collezione di sedute Slight prende il classico imbottito in contropiede. Come una pagina appena piegata, la scocca soffice vi abbraccia in modi diversi e si declina a seconda delle esigenze d'uso. Pensato sia per gli spazi d'attesa sia per gli ambienti domestici.

Thin as a leaf, Slight sofa collection takes the opposing view to the classic padded sofa. Like a little folded page, the soft body embraces you in different ways and comes out in several forms according to use requirements, suitable for waiting areas as well as domestic interiors.











WRAP

Christophe Bourban & Luciano Dell'Orefice

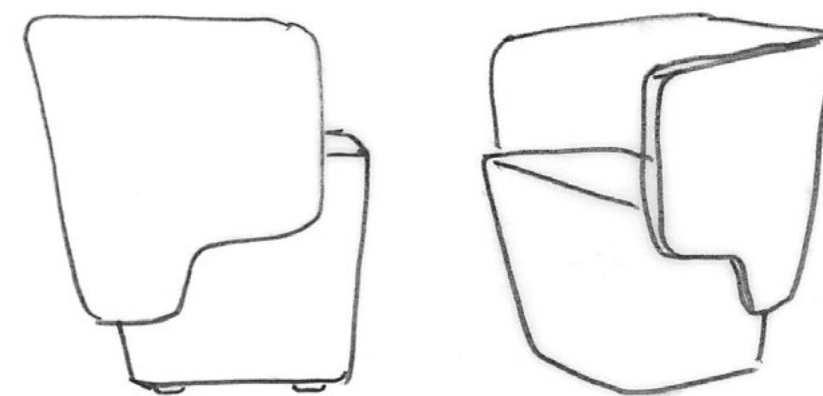

Caratterizzata dallo schienale avvolge il sedile, la collezione di sedute WRAP è composta da poltrona e divanetto disponibili in due diverse dimensioni. Alla versione standard si affianca una nuova variante "maxi", dalle dimensioni più generose, adatta oltre che per gli spazi attesa, anche per lounge e lobby di hotel.

The peculiar shape of the backrest, wrapped around the seat, gives WRAP sofa collection a unique identity. The collection is now completed by a new "maxi" version of both armchair and sofa, suitable for waiting areas, lounges and hotel lobbies.





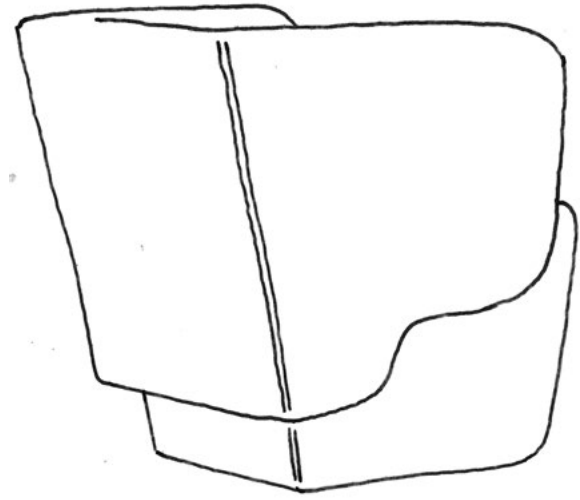







BIBLIS

Avio Calandrin + Eugenio Farina

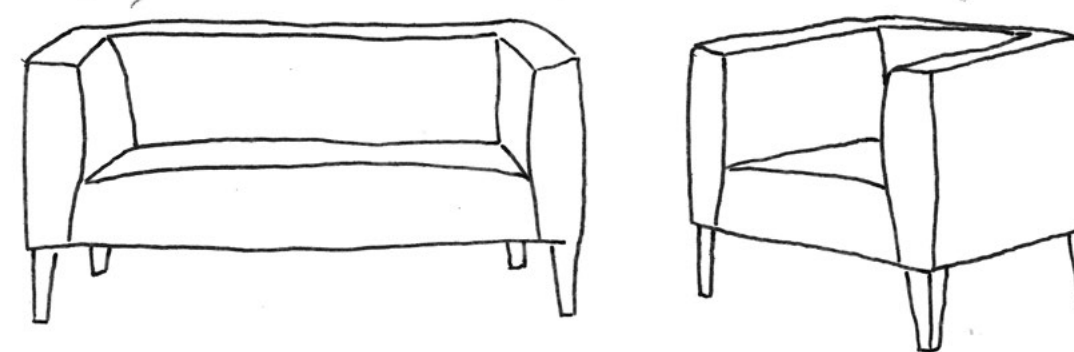

La serie di sedute Biblis si caratterizza per la presenza di valori estetici derivati dall'ambiente home trasferiti al settore contract, fondendo il calore della casa con il linguaggio minimalista tipico dello spazio pubblico; il risultato è una forma senza tempo, che si può adattare ad ambienti dalle molteplici destinazioni d'uso e coordinate estetiche.

The Biblis collection is characterized by aesthetic connotations typical of the home environment transferred to the contract, combining the warmth of home with the minimalistic language of the public space. The result is a timeless shape, adaptable to the flexibility of the modern working and domestic environment.





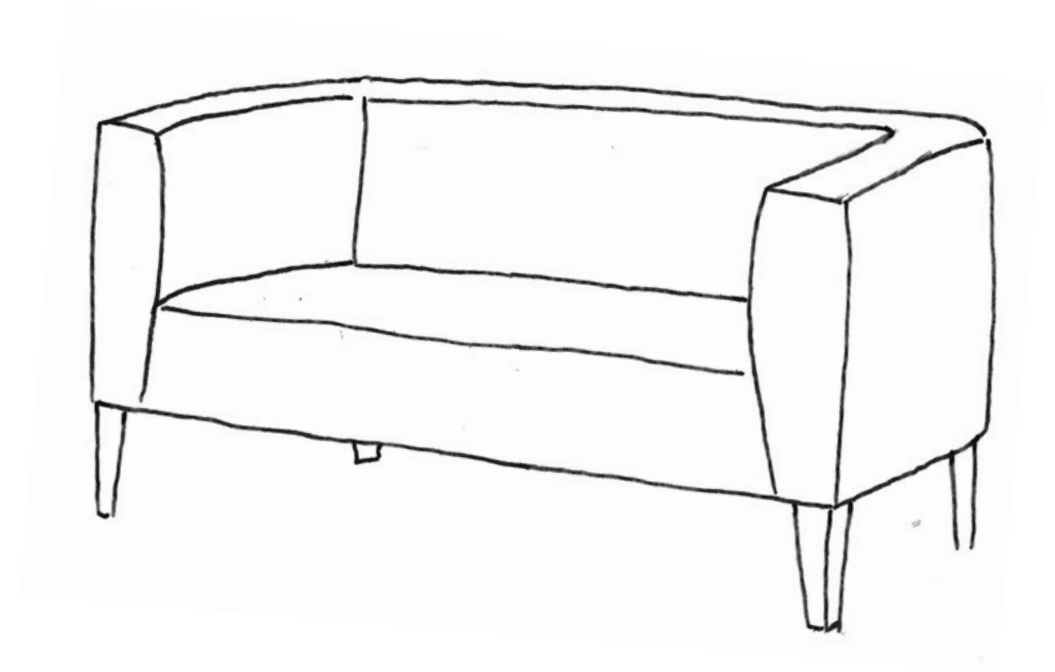

NOSMOKING

P+F Parisotto+Formenton

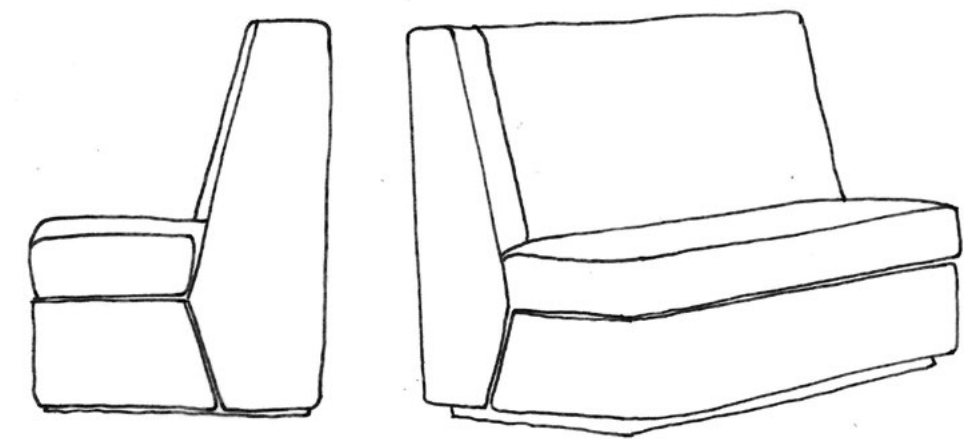

La famiglia di imbottiti Nosmoking si compone di poltrona e divano, concepiti per allestire zone d'attesa, grandi spazi, lounge. Il design dalle linee compatte ha proporzioni insolite che danno un carattere di forte riconoscibilità alla collezione. Lo schienale, insolitamente alto, avvolge con due corte orecchie inclinate la persona seduta donando un effetto inaspettato di privacy e comodità. Struttura, seduta e schienale giustapposti tra loro come elementi indipendenti formano un'intersezione delle linee dinamiche che connota fortemente il fianco.

A family of padded seats composed by armchair, and sofa designed to fit inside waiting areas, large spaces and lounge. The design is defined by compact lines and unusual proportions, which makes Nosmoking standing up among the classic seating collections. The backrest, unusually high, embraces the user with two short "ears", providing an unexpected effect of privacy and comfort. Structure, seat and backrest are juxtaposed as independent elements that create dynamic lines when the intersect each other, giving a strong peculiarity to the side view.







POSEIDONE

Leonardo Rossano

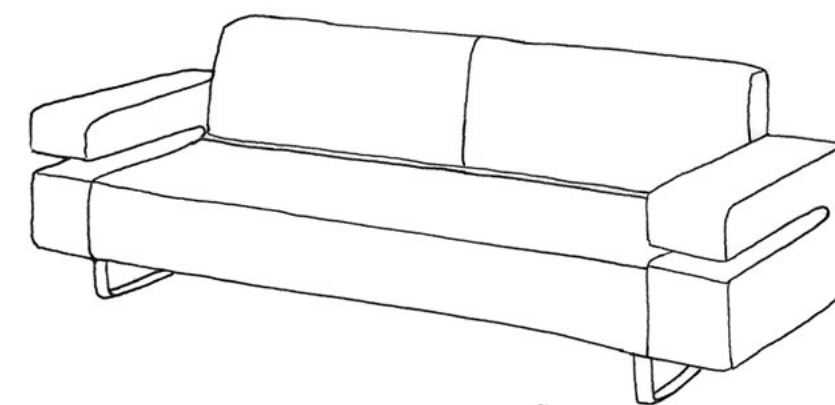

Sintesi di gusto classico e contemporaneo, presenta volumi solidi, che pur nel rigore delle sue forme lo rendono protagonista dell'ambiente in cui viene inserito. La versione Mini ne consente il posizionamento anche in ambienti più contenuti.

A mix of classic and contemporary touch makes this sofa a peculiar piece of furniture, characterized by solid volumes. The smaller Mini version makes it fit even in smaller environments.

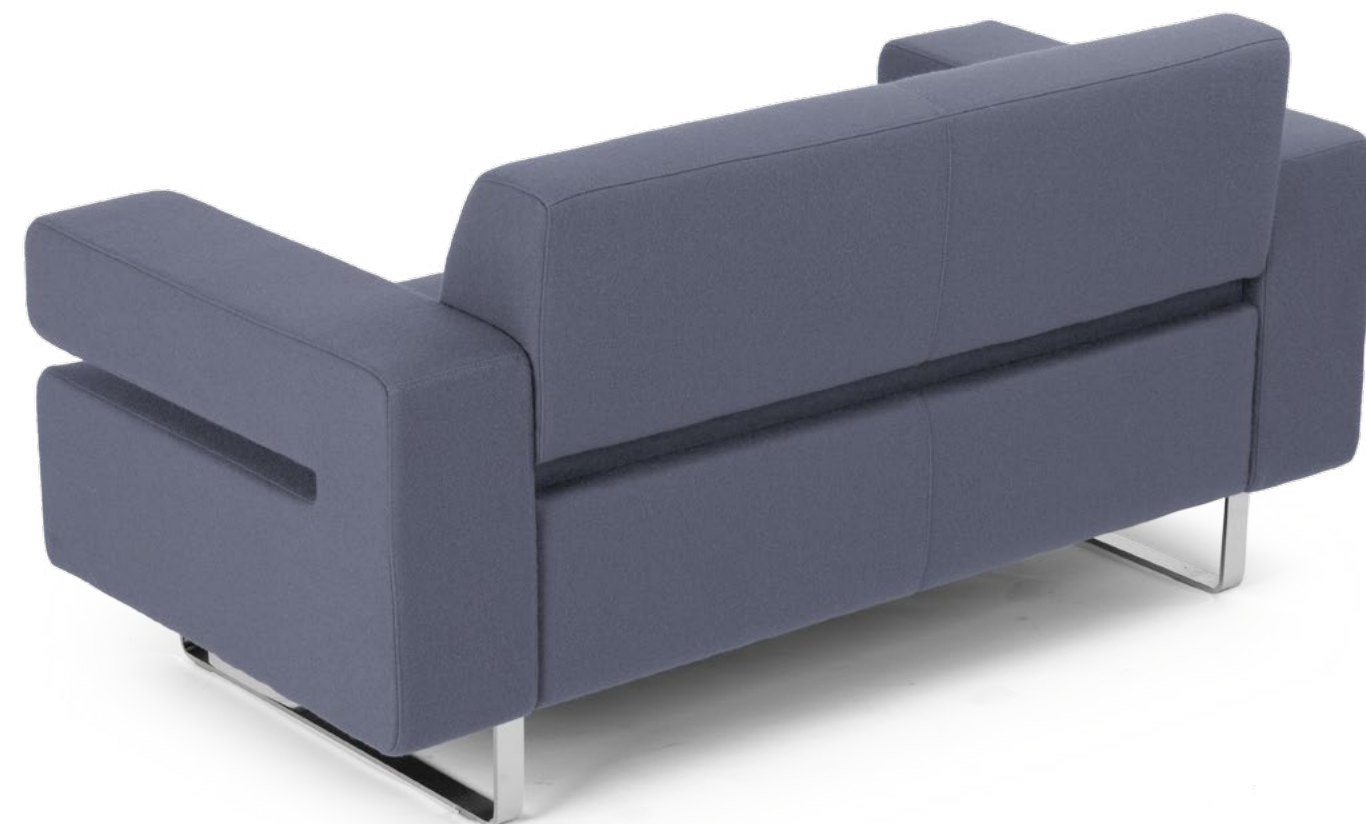

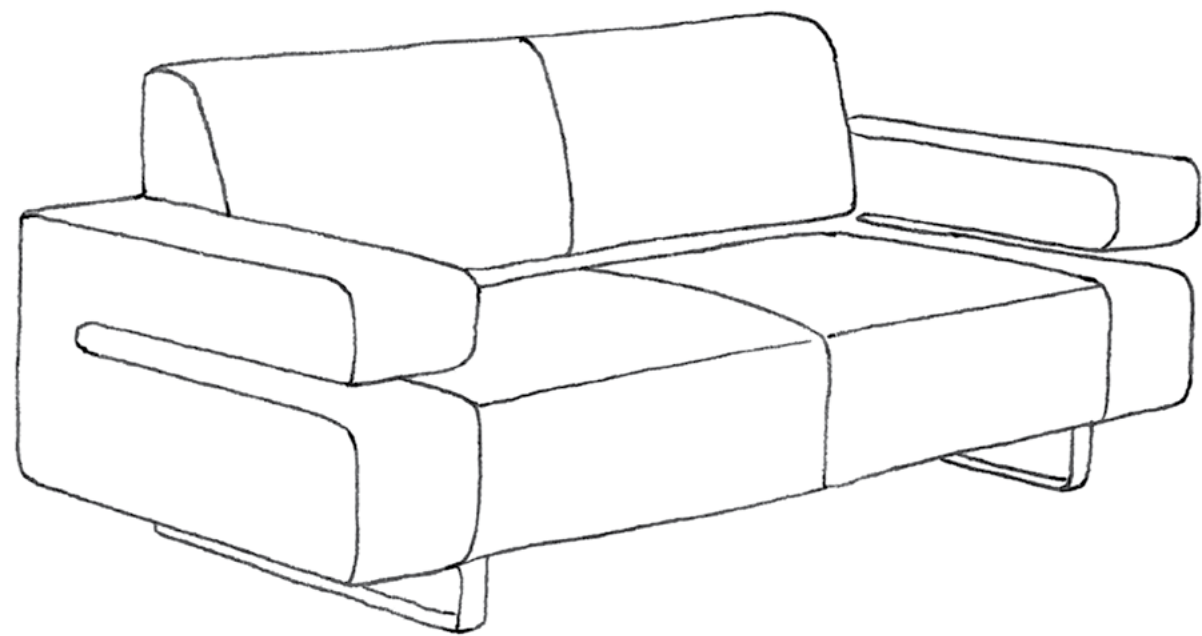

ALADDIN

Leonardo Rossano

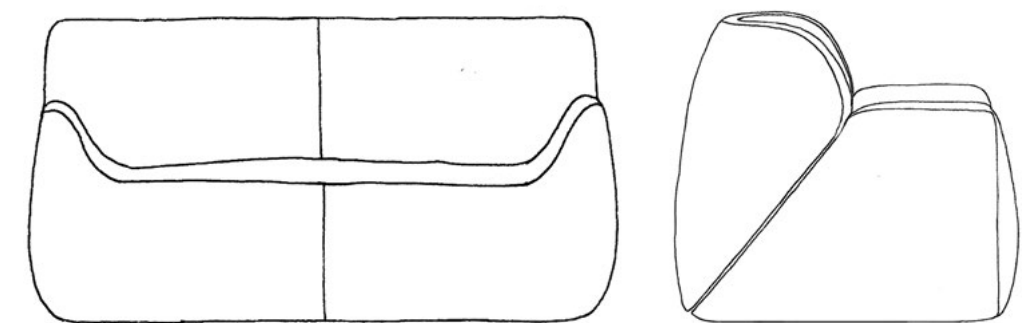

Aladdin è il confortevole sistema di poltrone e divani caratterizzato da forme sinuose ed avvolgenti; è stato ideato per gli spazi pubblici destinati all'attesa e al relax.

La sapiente manifattura artigianale contribuisce alla creazione di un divano dall'aspetto intrigante, indicato per zone informali di riposo anche in ambiti domestici.

Aladdin is the comfortable seating system characterized by sinuous and embracing shapes, it's made for waiting areas and relaxing public spaces.

The skillful handcrafted production contributes to the creation of an intriguing sofa, perfect for informal spaces, both public or domestic.





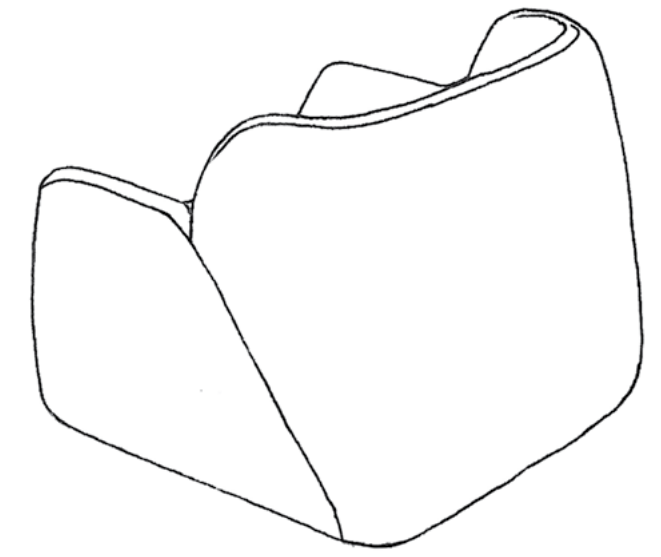

HEBE

Favaretto & Partners

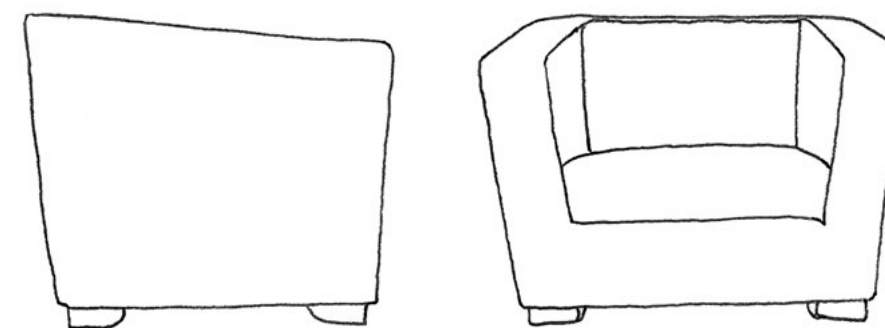

Divano caratterizzato da linee essenziali e rigorose per una pulizia d'immagine e grande comfort di seduta. Sono disponibili diversi elementi preconfigurati: poltrona, divano a due o tre posti oppure componibile con elementi centrali e terminali, che consentono molteplici soluzioni lineari e/o ad angolo.

Sofa defined by essential and rigorous shapes, which give a very clean design and high comfort. Armchair, two and three seaters sofas are available as well as composable central and side elements for various linear and corner configurations.









MARINA

Leonardo Rossano



La sedia Marina è caratterizzata da geometrie dinamiche e lineari. La sagoma sfaccettata della scocca in compensato interagisce con la struttura che la sostiene generando un sistema di sedute dalla spiccata personalità. Particolarmente indicata per il settore del contract, è disponibile anche imbottita e può essere completata da braccioli e altri accessori.

The design of Marina is defined by linear and dynamic geometries. The shape of the seat in multilayered wood interacts with the metal frame, generating a system of marked personality. Particularly recommended for the contract branch, it is available also in the padded version and can be customized with armrests and other accessories.







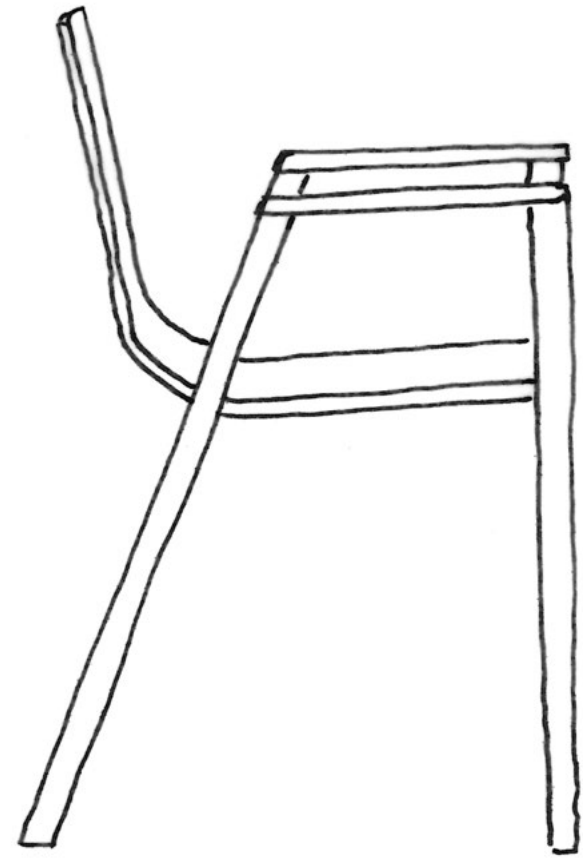

KAY

Leonardo Rossano

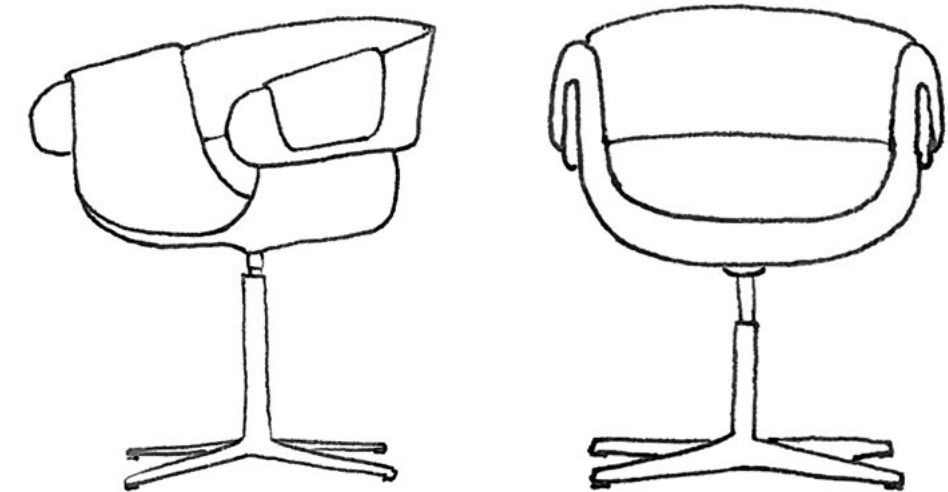

La sedia girevole Kay nasce dall'unione di due semplici scocche in multistrato curvato. L'elemento della seduta avvolge i braccioli dando l'illusione di una funzione strutturale del morbido rivestimento. Il risultato di questo ludico utilizzo dei materiali è una seduta dalla disinvolta eleganza che può essere utilizzata in zone d'attesa e relax o nell'area office all'interno di spazi privati.

The swivel chair Kay comes from the combination of two simple elements of bent plywood. The seat wraps the armrests giving the illusion of the soft padding's structural function. The result of this playful use of the materials is a nonchalant elegant chair that can be used in waiting and relax areas in offices or in an office zone in private spaces.





GEA

Leonardo Rossano

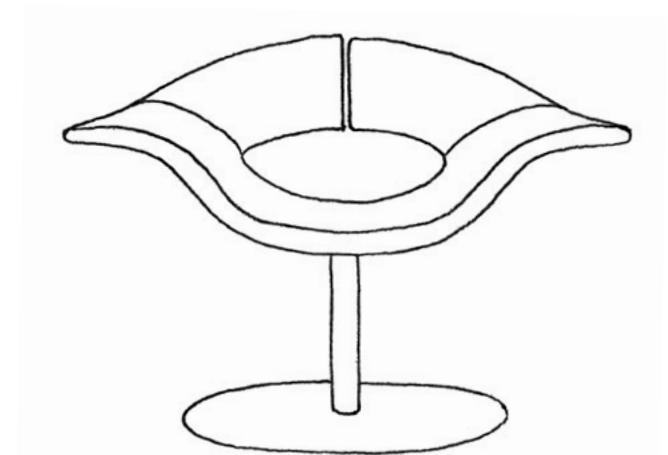

Poltroncina girevole studiata per lo spazio d'attesa, può essere facilmente collocata anche in ambiente domestico grazie all'aspetto accattivante, frutto di una ricerca sulle possibilità espressive di una singola superficie. Il comfort della poltrona è rafforzato dalle diverse posizioni di seduta e dalla possibilità di utilizzare gli ampi braccioli come base d'appoggio per computer portatili di piccole dimensioni.

Swivel chair designed for waiting spaces, it can be easily placed in house environments thanks to its attractive appearance, as a result of the research on the expressive possibilities of a single surface. The high comfort of the chair is enhanced by different seating positions and the possibility to use its wide armrests as a support for small laptops.





GRILLO

P+F Parisotto+Formenton

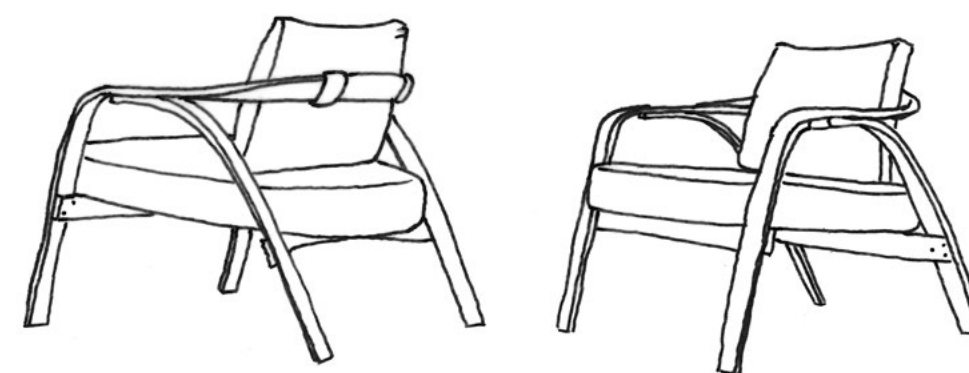

Grillo è caratterizzato dal contrasto tra la struttura, le zampe, dinamica e caratterizzata da curve tese ed archi contrapposti che si incontrano e la seduta che vi si inserisce come giustapposta.

Il nastro in lamellare termocurvato, senza mai cambiare la propria sezione ma solo attraverso delle calibrate torsioni, crea in continuità prima il piede, poi il bracciolo e lo schienale come un unico segno che si muove nello spazio. Grande valenza estetica ha il contrasto, con cui si può giocare, tra il colore e la caratterizzazione materica degli elementi in legno e di quelli imbottiti.

Grillo is defined by the contrast between the structure, the paws, dynamic and characterized by stretched curves and counterposed arches, gathering with the seat in between, juxtaposed.

The thermo curved wooden element, without ever changing its section but only through calibrated torsions, creates the foot, the armrest and the backrest as a unique line moving through the space. The contrast between the colors and the materials is the main aesthetic feature of this collection.







PINCETTES

Luciano Dell'Orefice

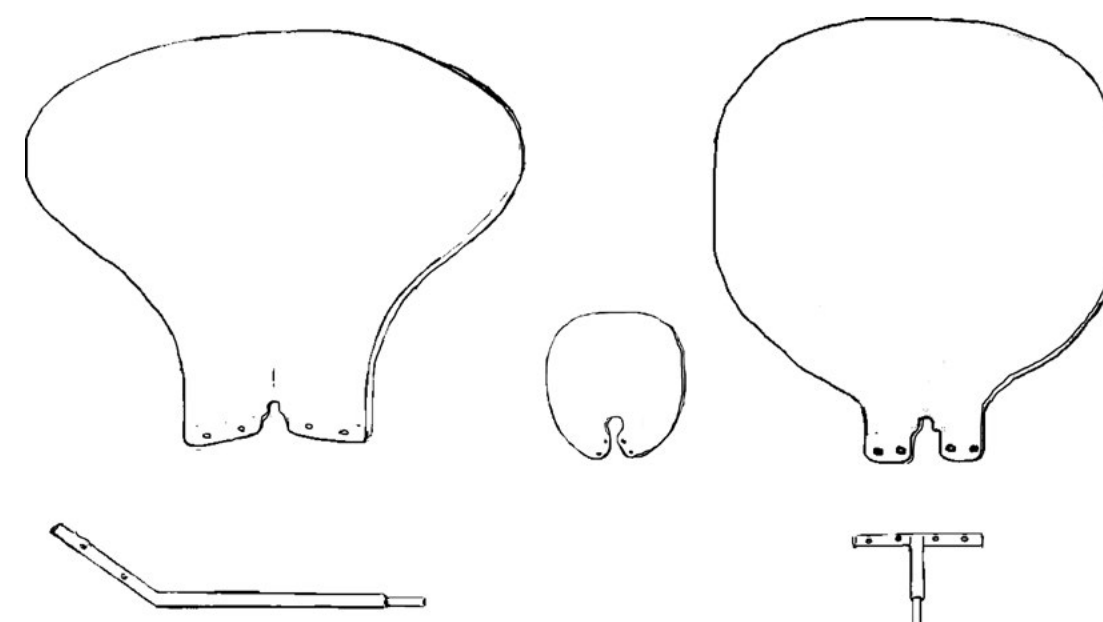
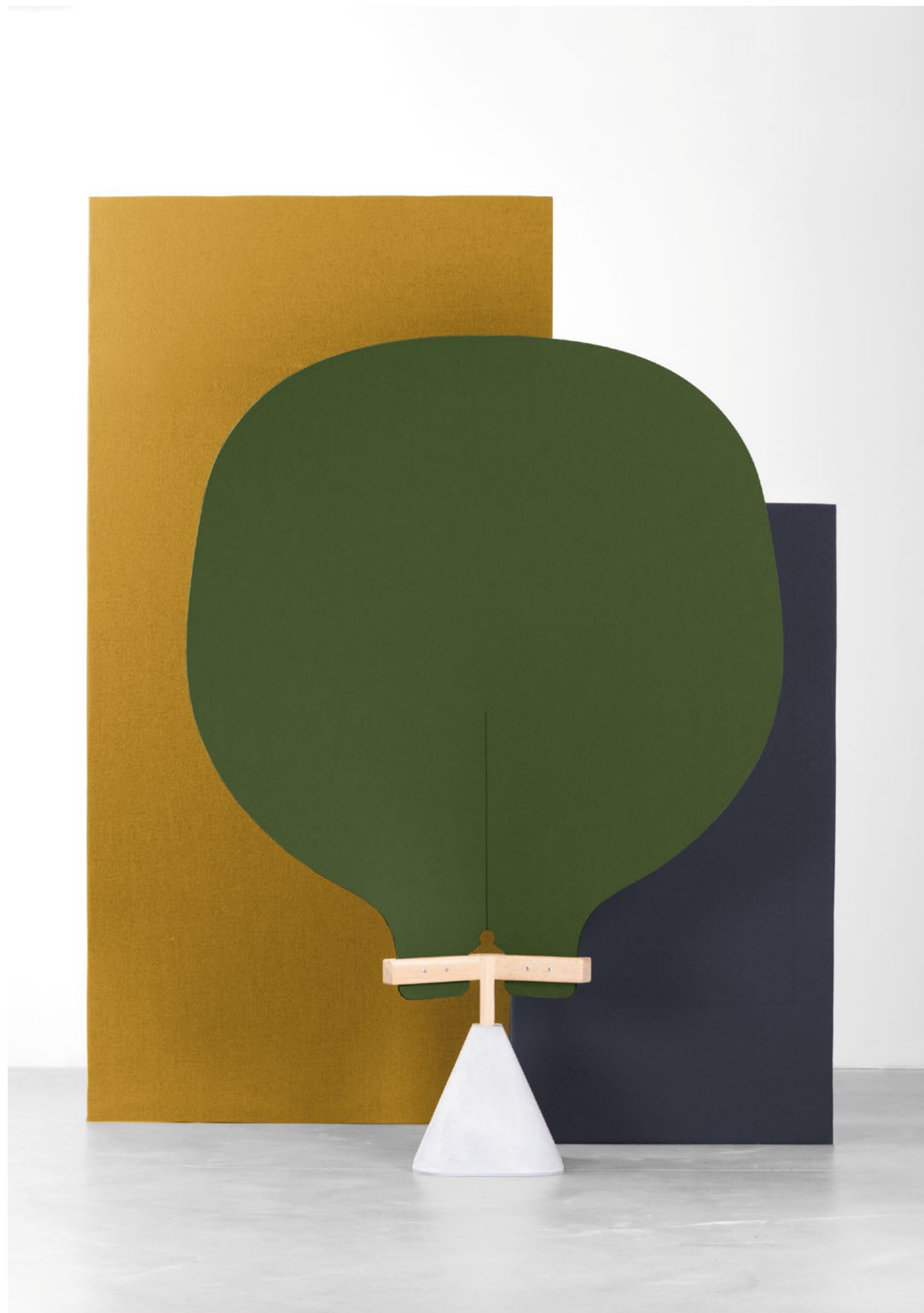

Pincettes è una collezione di pannelli divisori che garantiscono un elevato livello di privacy senza rinchiodare troppo l'utilizzatore, nel rispetto del rito dei momenti di pausa quotidiani. La logica costruttiva è molto semplice ed è adatta per ricavare piccole isole di pace all'interno dell'ambiente di lavoro, dove poter riposare, leggere, chiacchierare o fare una pausa in tutta intimità. Il modulo è composto da un pannello in fibra di poliestere termoformato tra due strati di tessuto, pinzato all'interno di una struttura in legno massello inserita su un piedistallo di cemento grezzo o fissata a soffitto.

Pincettes is a set of open dividers that offers ways to isolate without encasing the users, respecting their habits when it's break time. The construction is very simple and is adapted to work spaces making small and quiet islands where you can rest, read, chat or take a nap out of sight. The module is composed by a multilayer panel of polyester and textile pinched in a solid wood structure and fixed to a concrete base or to the ceiling. Pincettes having the double function of privacy divider and acoustic insulation adapts itself, by its great chromatic and typological options, to any space.

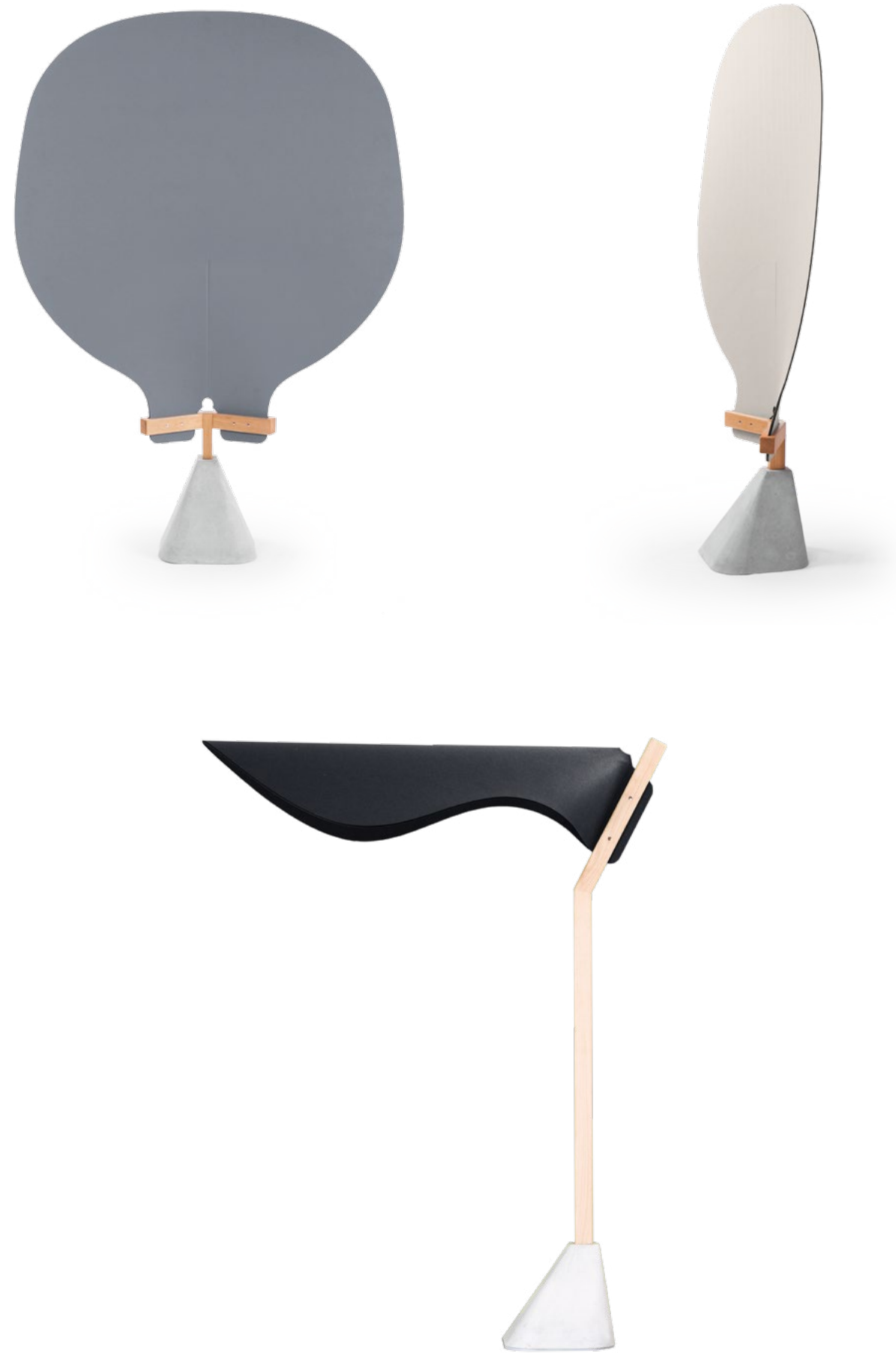



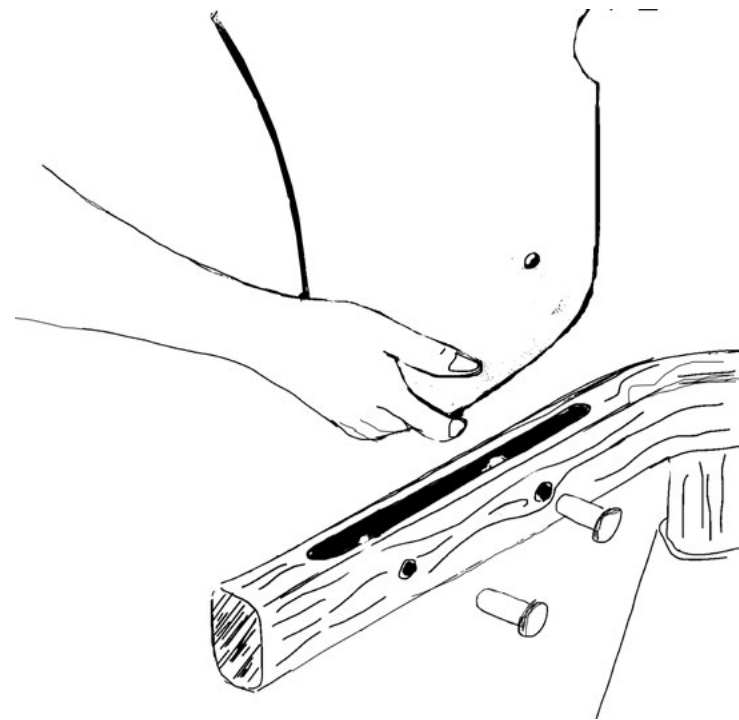



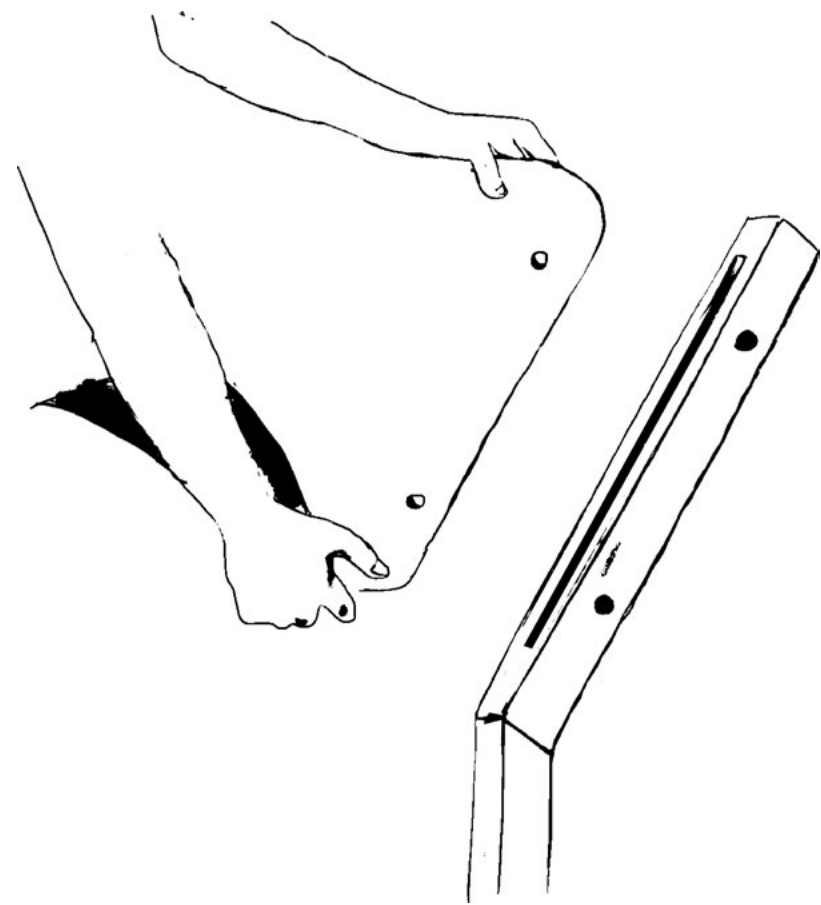



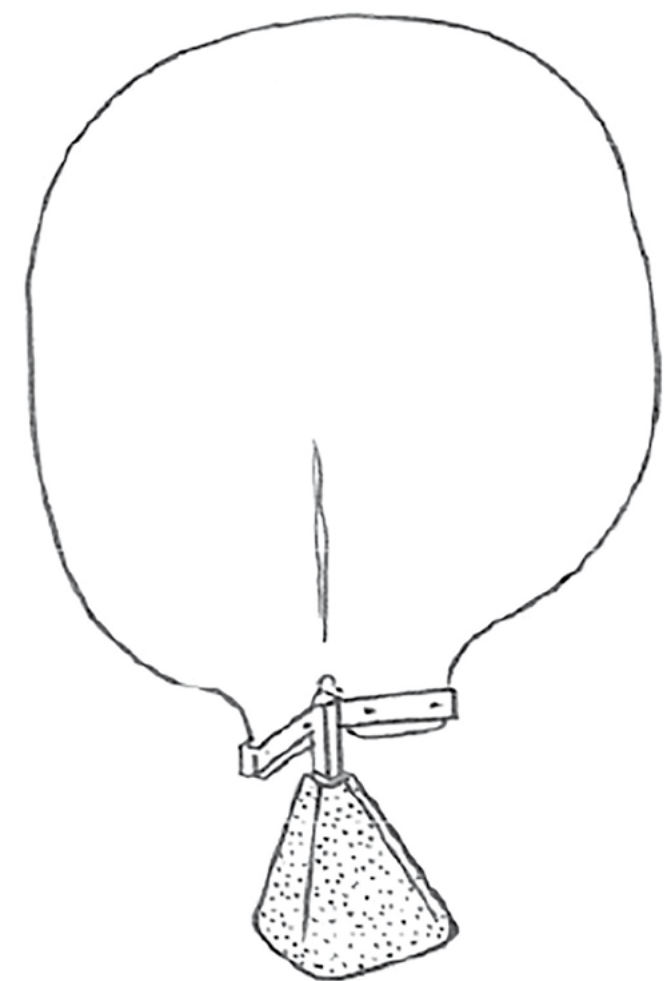



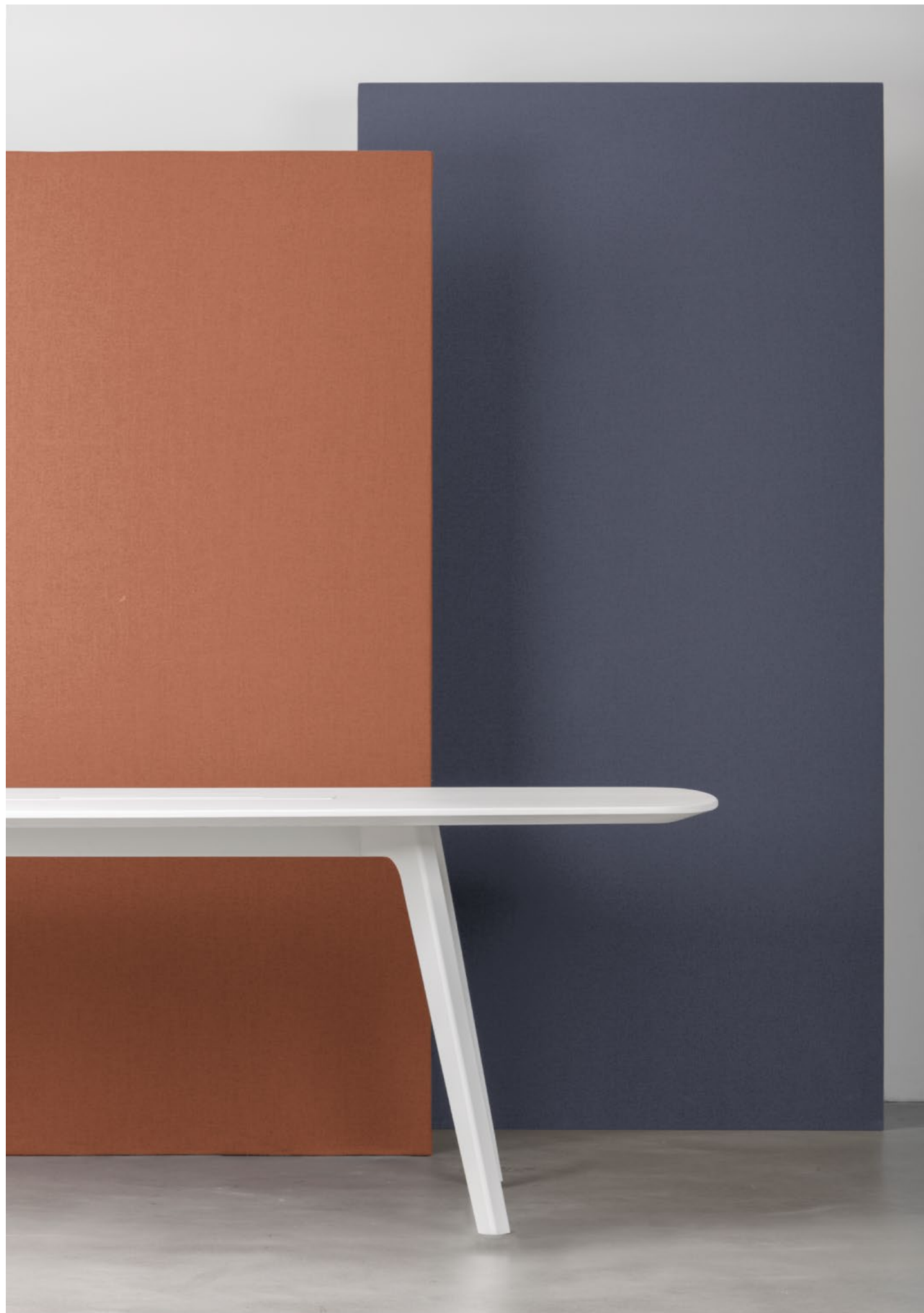

WING

P+F Parisotto+Formenton

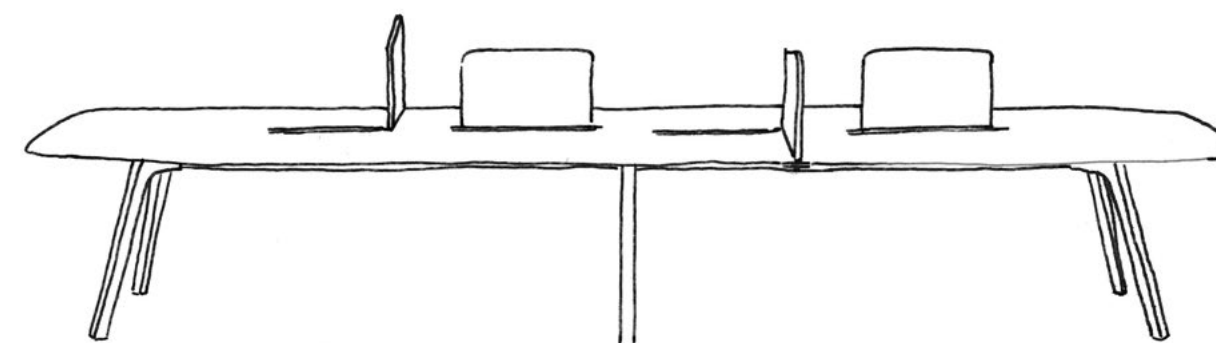

Wing è un tavolo che nasce per gli ambienti di lavoro, ma può essere declinato in contesti di home-office o domestici. Si caratterizza per la struttura sottostante leggera, che trae ispirazione dai cavalletti dei tavoli da lavoro, e per il top dalle forme arrotondate "a saponetta" dalle linee molto contemporanee.

Dotato di grande flessibilità d'uso, si accompagna ad accessori come i pannelli divisorii imbottiti, la lampada centrale in ottone e i vassoi in legno e metallo che si inseriscono, grazie a un sistema di agganci magnetici, sul grande canale centrale adibito anche alla distribuzione elettrica e all'organizzazione cavi.

Wing is a table created for working areas, but it can also fit inside a home-office or domestic environment. It is characterized by a wooden frame inspired by the sawhorse of the working tables, and the rounded shape of the top with its contemporary lines.

Defined by great flexibility, Wing can be completed with acoustic panels, a brass reading lamp and wooden or metal trays that are installed on the large central channel through a magnetic fixing system. Power supply and cable management are allocated on the same central channel.



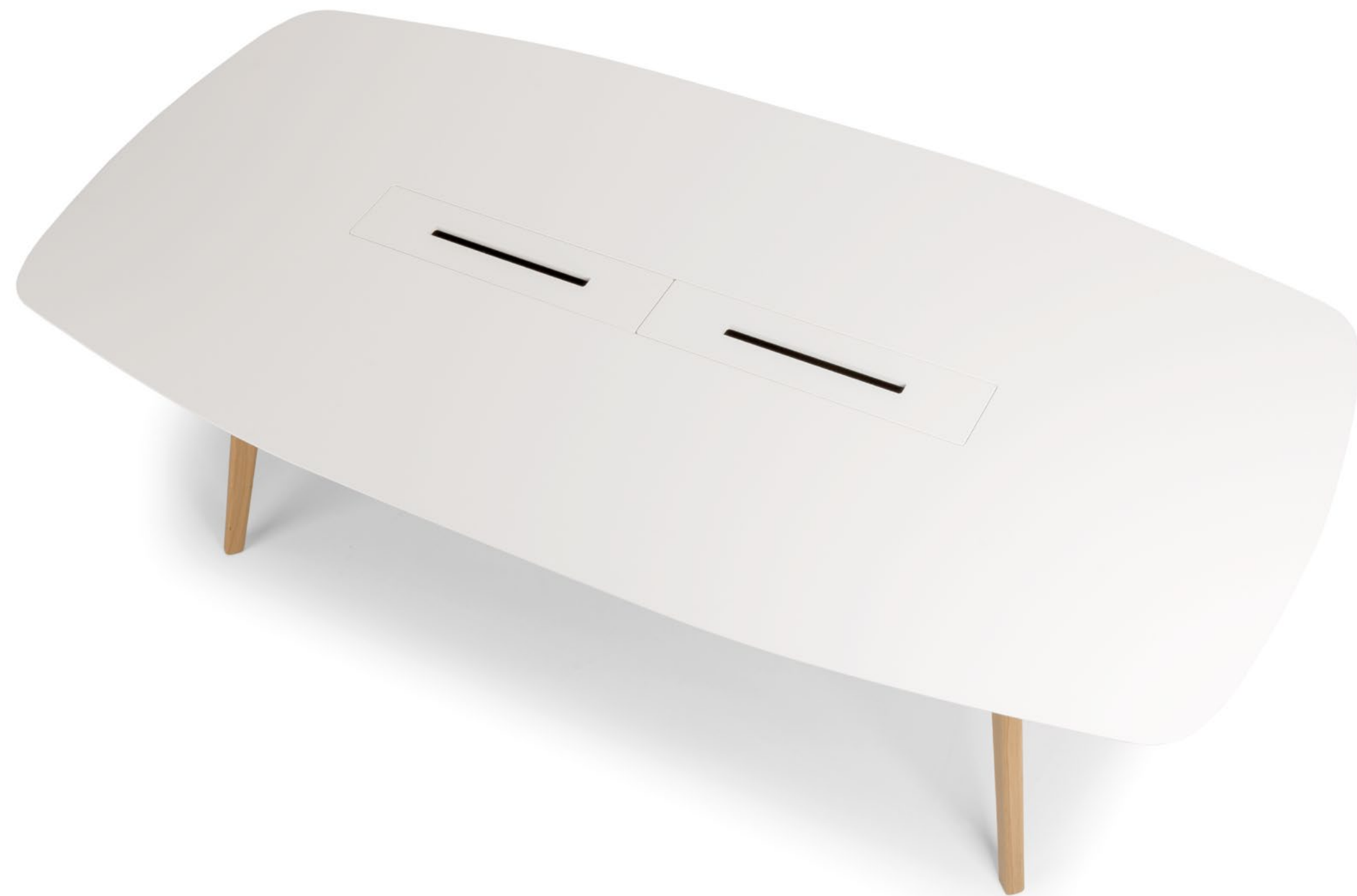



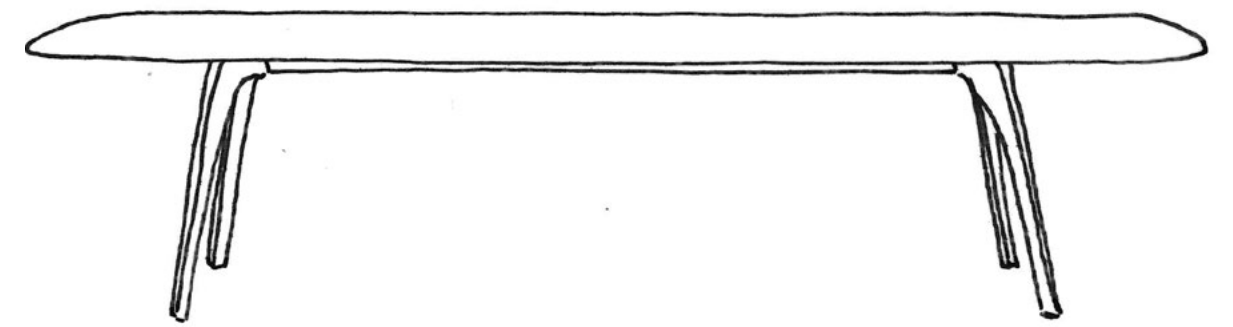







COMPLEMENTS

ZERO

Orlandini Design

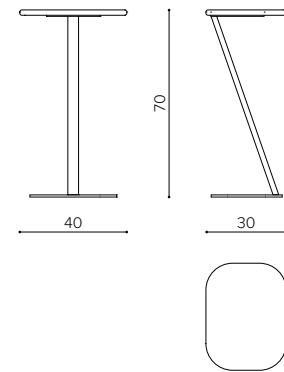

ORACLE

Orlandini Design

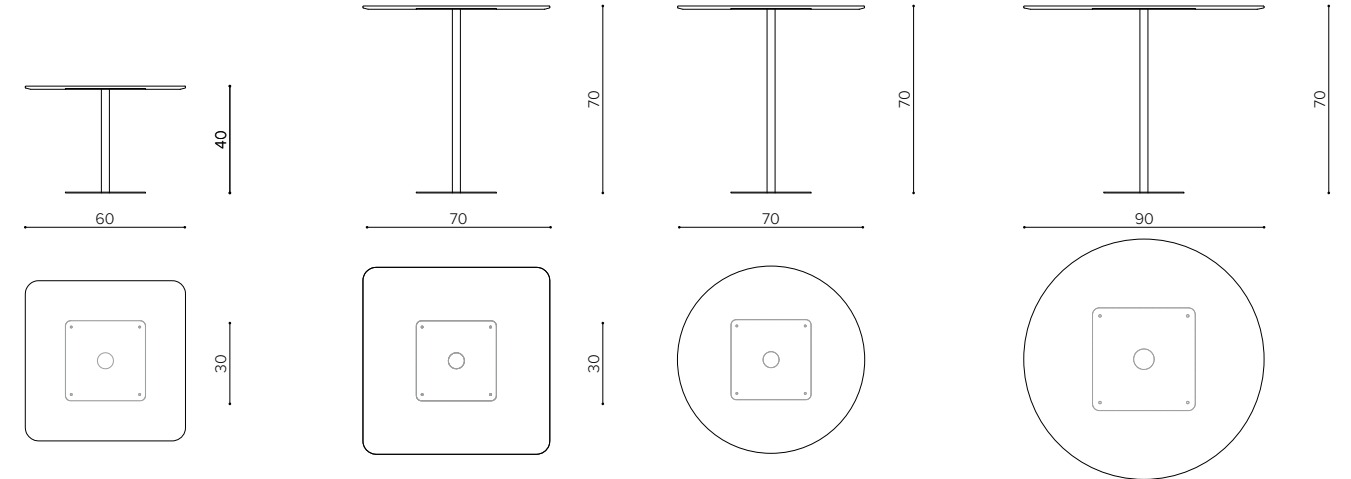

MILLEPIEDI

P+F Parisotto+Formenton

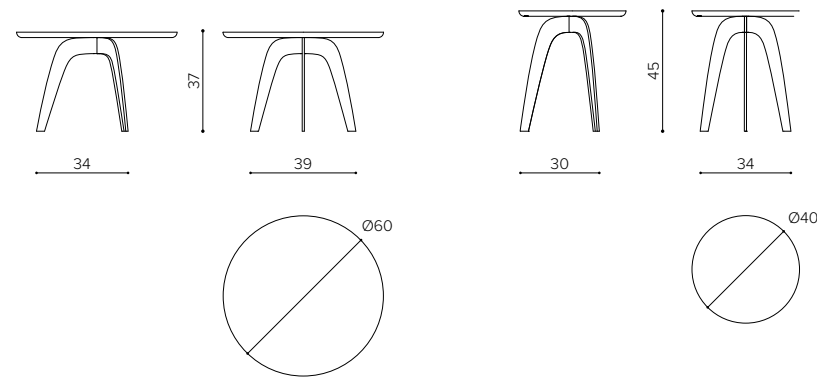

WRAP

Christophe Bourban & Luciano Dell'Orefice

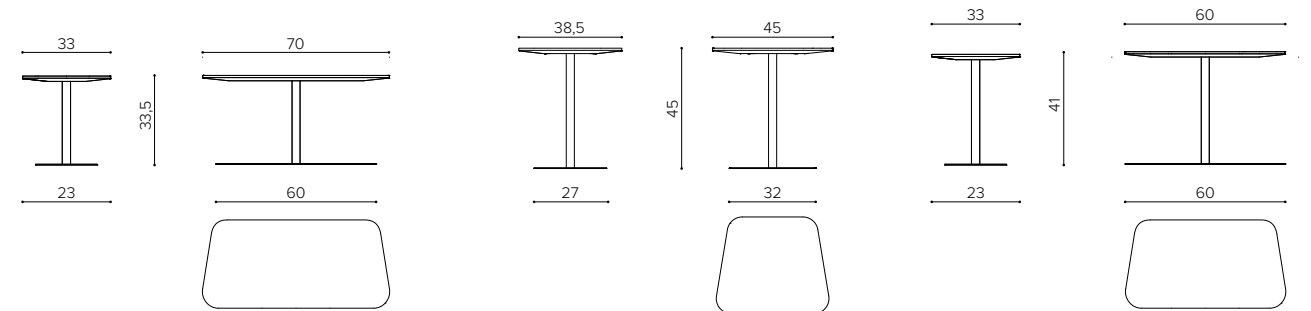

TECHNICAL FEATURES

AA 9090
poltrona alta, base in acciaio
high back armchair, steel base

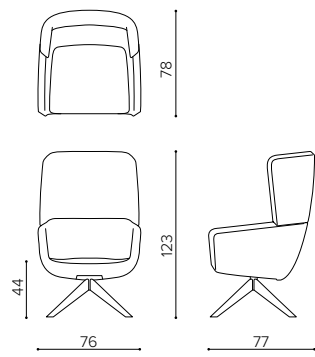

AA 909P
base a piastra • plate base

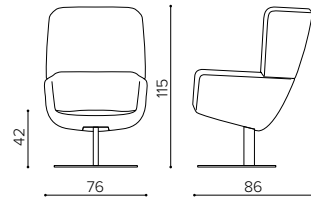

AA 9095
base a slitta • sled base

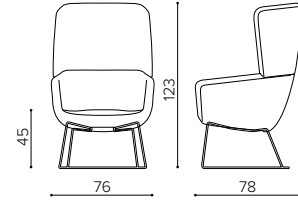

AA 9099
base in legno • wooden base

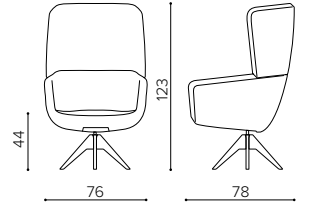

AA 909S
base in legno • wooden base

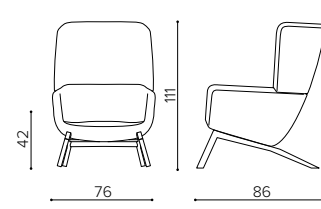

AA 909R
base a dondolo • rocking base

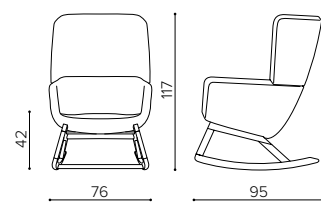

AA 8090
poltrona media, base in acciaio
mid back armchair, steel base

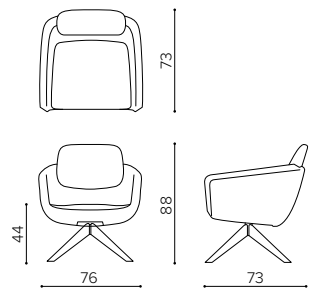

AA 809P
base a piastra • plate base

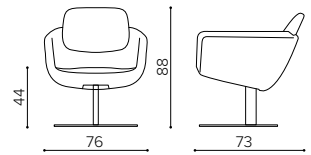

AA 8095
base a slitta • sled base

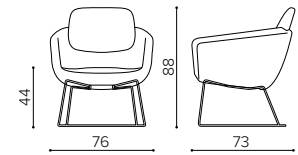

AA 8099
base in legno • wooden base

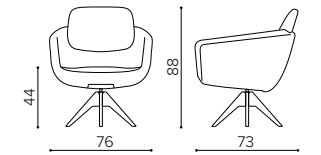

AA 7090
poltrona bassa, base in acciaio
low back armchair, steel base

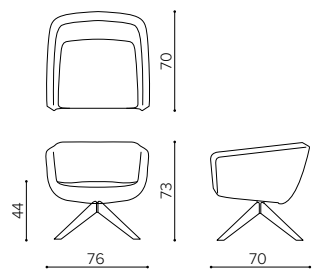

AA 709P
base a piastra • plate base

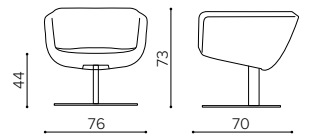

AA 7095
base a slitta • sled base

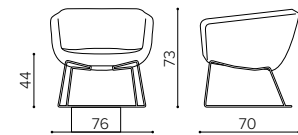

AA 7099
base in legno • wooden base

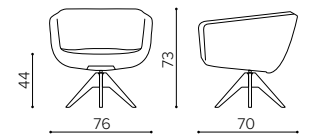

AA 6099
poltrona piccola, schienale alto, base in legno
small armchair, high backrest, wooden base

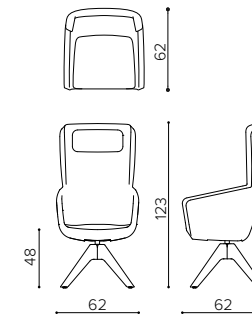

AA 609C
base su ruote • casters base

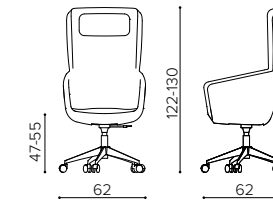

AA 5099
poltrona piccola, schienale basso, base in legno
small armchair, low backrest, wooden base

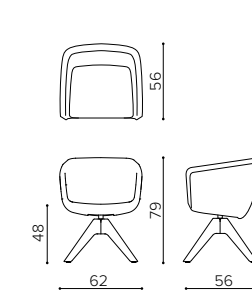

AA 5095
base a slitta • sled base

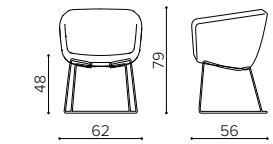

AA 509C
base su ruote • casters base

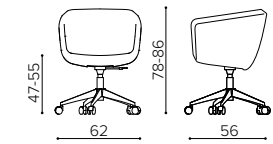

AA 5098
base in alluminio • aluminum base

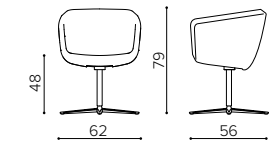

AA 4090
poltroncina mini, base in acciaio
mini armchair, steel base

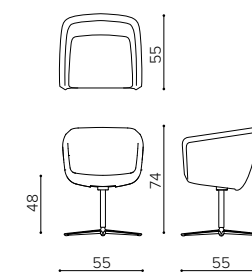

AA 409C
base su ruote • casters base

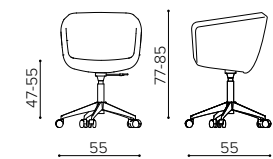

COLORS

ACCIAIO / STEEL

LEGNO / WOOD

La finitura standard del legno é il frassino naturale. Su richiesta sono disponibili altre essenze e colorazioni customizzate su tinta RAL o PANTONE.

Le finiture standard del telaio a slitta sono il bianco e il cromato; per gli altri basamenti in acciaio il grigio antracite. Su richiesta sono disponibili colorazioni customizzate su tinta RAL o PANTONE.

Standard finishing for wood is natural ash. Customized RAL or PANTONE colors are available upon request.

Standard finishings for the sled frame are chrome or white; for other bases it is dark grey. Customized RAL or PANTONE colors are available upon request.

AL 1000

poltrona • armchair

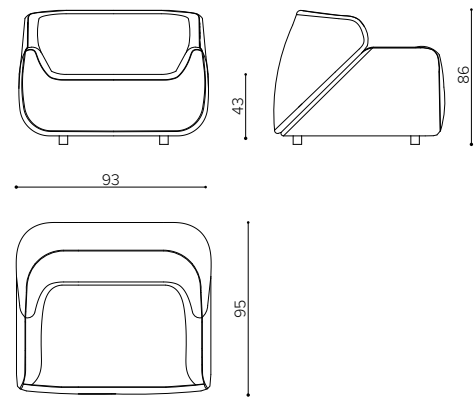
**AL 2000**

divano 2 posti • 2 seater sofa

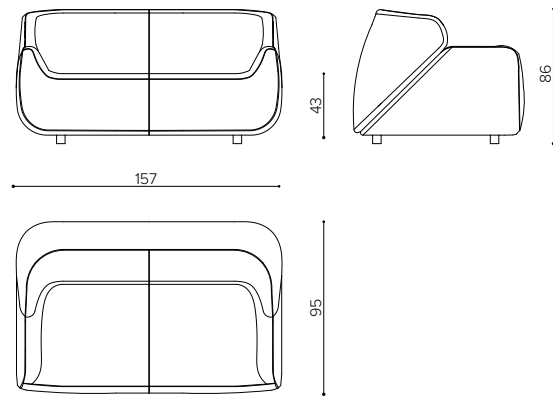
**AL 3000**

divano 3 posti • 3 seater sofa

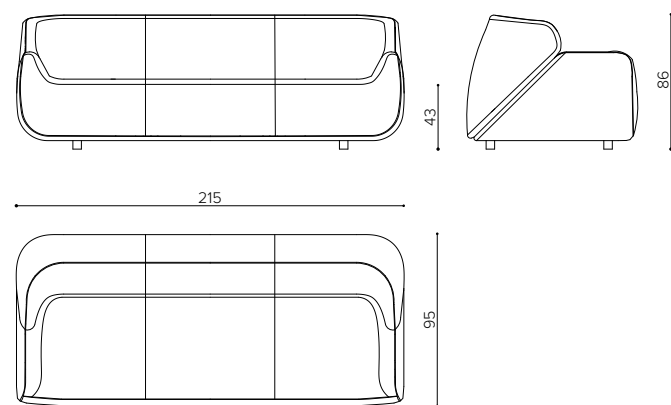
**BB 1000**

poltrona • armchair

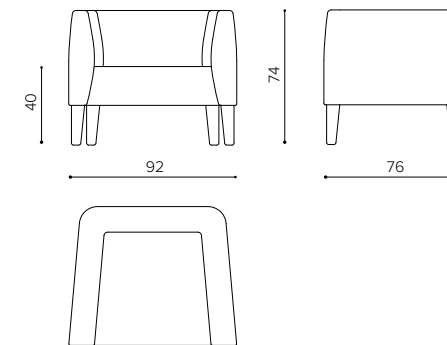
**BB 2000**

divano 2 posti • 2 seater sofa

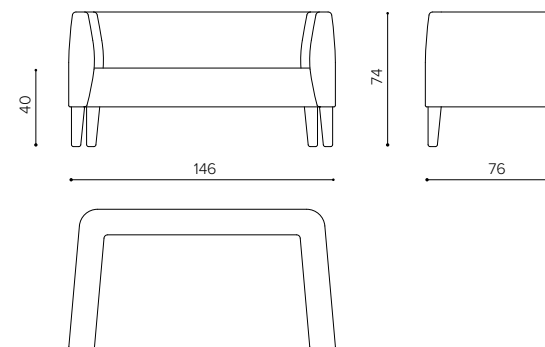
**BB 3000**

divano 3 posti • 3 seater sofa

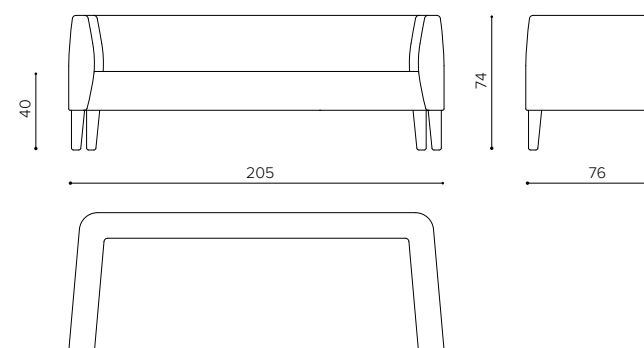
**COLORS****ACCIAIO / STEEL**

7016

RAL

La finitura standard dei piedini in acciaio è grigio antracite. Su richiesta sono disponibili colorazioni customizzate su tinta RAL.

Standard finishing for the steel feet are grey anthracite. Customized RAL colors are available upon request.

CL 100R
poltrona destra • right armchair

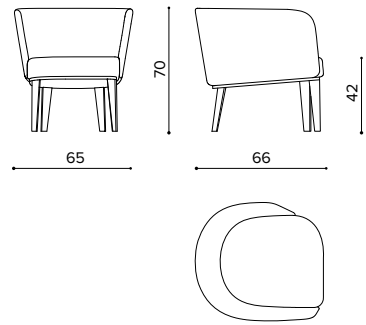

CL 100L
poltrona sinistra • left armchair

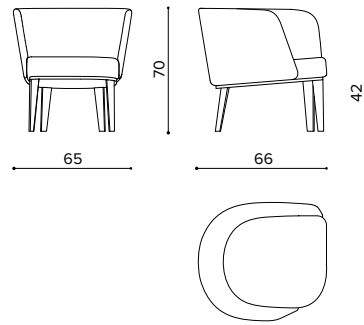

CL 200R
dormeuse destra • right day-bed

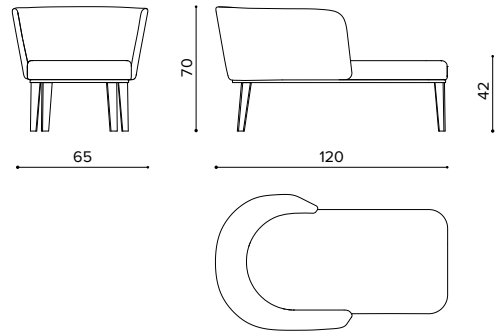

CL 200L
dormeuse sinistra • left day-bed

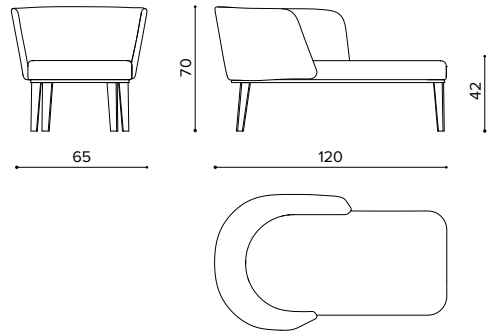

COLORS

ACCIAIO / STEEL



Le finiture standard del telaio in acciaio sono grigio chiaro, grigio antracite, verde o blu. Su richiesta sono disponibili colorazioni customizzate su tinta RAL.

Standard finishings for the steel structure are light grey, anthracite grey, green or blue. Customized RAL colors are available upon request.

DN 3000
panca 3 posti • 3 seater bench

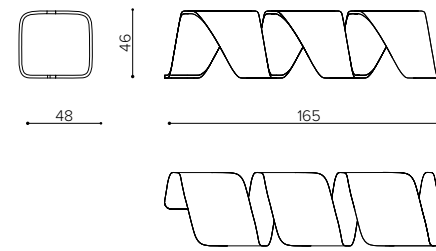

DN 4000
panca 3 posti • 3 seater bench

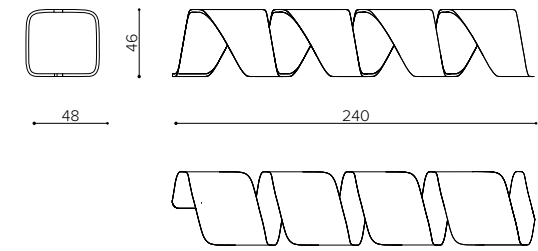

DN 5000
panca 3 posti • 3 seater bench

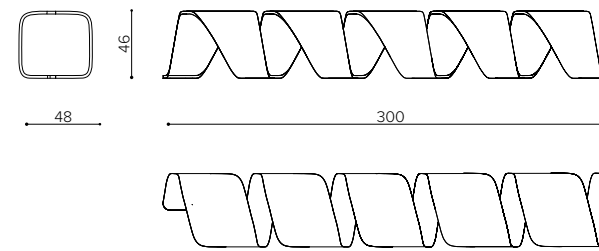

DN 1000
modulo posto extra • extra seat module

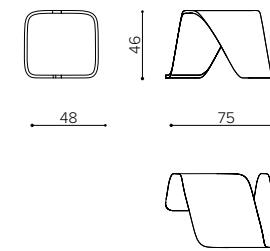

DN 10R0
panca curva • curved bench

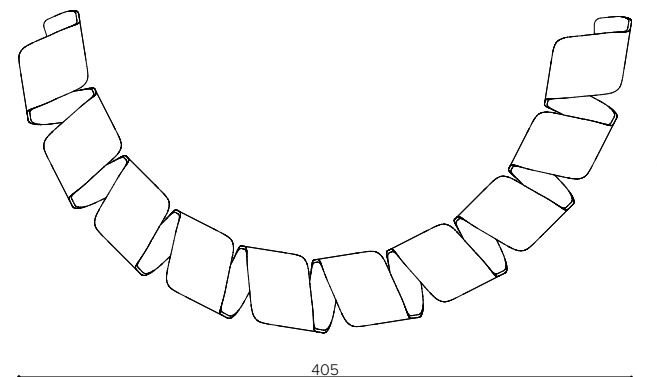

COLORS

LEGNO / WOOD

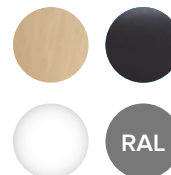

Le finiture standard del legno sono il rovere naturale, tinto wengè o laccato bianco. Su richiesta sono disponibili altre essenze e colorazioni customizzate su tinta RAL o PANTONE.

Standard finishings for wood are natural oakwood, wengè or painted oakwood. Customized RAL or PANTONE colors are available upon request.

Le finiture standard del legno nella versione bicolore sono il rovere tinto wengè abbinato al rovere tinto rosso. Su richiesta sono disponibili altre essenze e colorazioni customizzate su tinta RAL o PANTONE.

Standard finishings for two colors version are red painted and wengè oakwood. Customized RAL or PANTONE colors are available upon request.

GA 100D

poltrona su base cromata a disco • chrome disc base chair

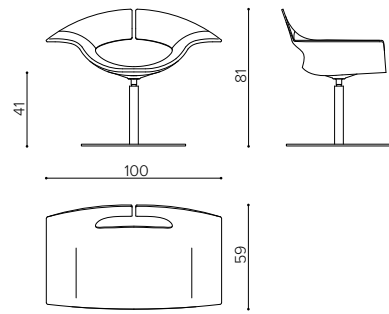
**GA 1008**

poltrona su base 4 razze in alluminio • 4 legs aluminum base chair

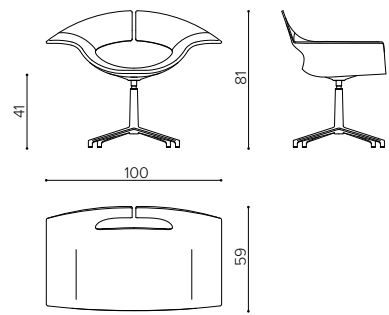
**GR 1000**

poltrona • armchair

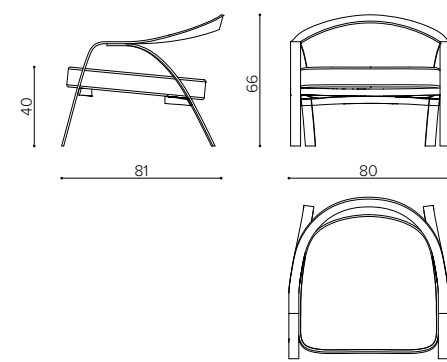
**GR 1050**

cuscino/backrest • cushion/backrest

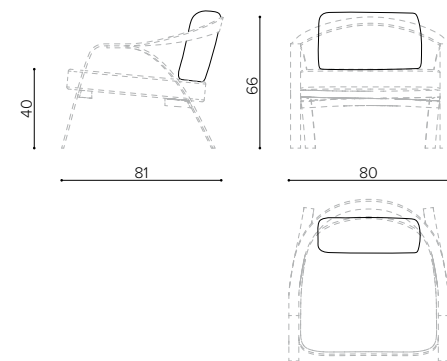
**HB 1000**

poltrona • armchair

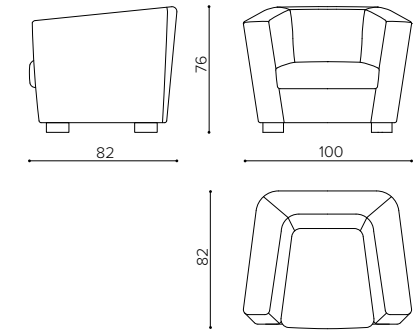
**HB 2000**

divano 2 posti • 2 seater sofa

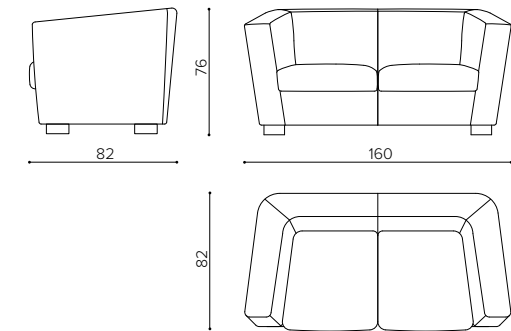
**HB 2000**

divano 3 posti • 3 seater sofa

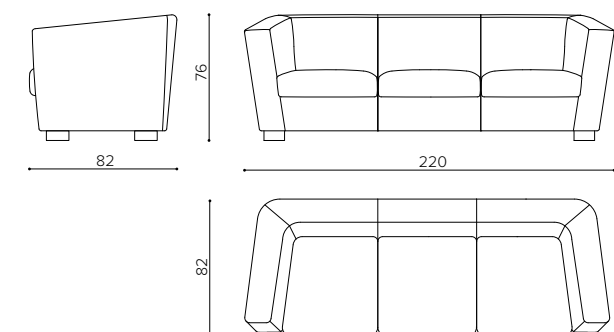
**COLORS****LEGNO / WOOD**

Le finiture standard del legno sono il faggio e rovere naturali o nero tinto all'anilina. Su richiesta sono disponibili altre colorazioni customizzate su tinta RAL.

Standard finishings for wood are natural oakwood and beechwood or black aniline dyed. Customized RAL colors are available upon request.

HV 9798

poltrona alta , meccanismo synchron
• high back armchair, synchron mechanism

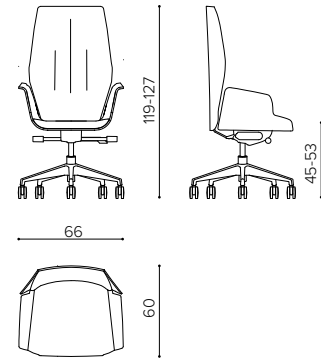
**HV 8798**

poltrona media, meccanismo synchron
• medium back armchair, synchron mechanism

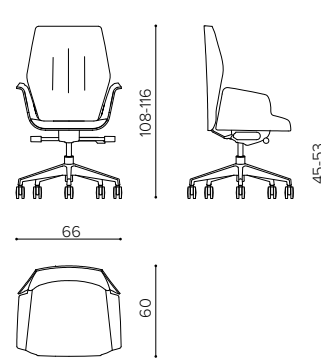
**HV 4099**

sedia 4 gambe • 4 legs chair

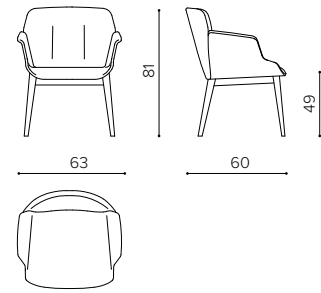
**HV 4098**

sedia su base girevole • cross base chair

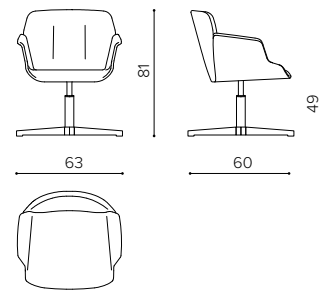
**HV 7098**

sedia base su ruote • chair on casters

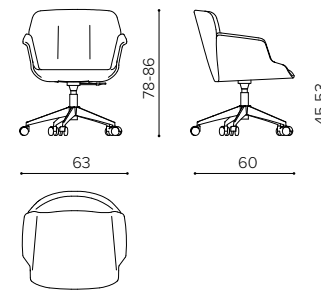
**HV 1000**

poltrona • armchair

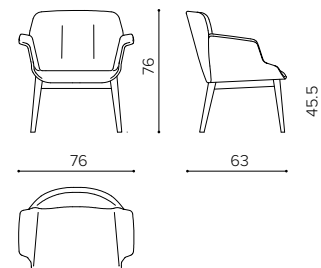
**HV 2000**

divanetto 2 posti • 2 seater sofa

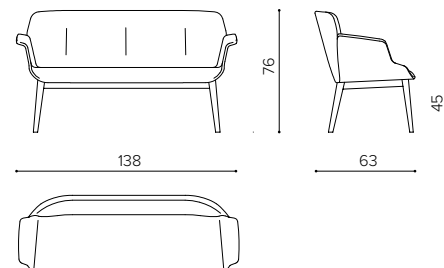
**COLORS****LEGNO / WOOD**

La finitura standard del legno è il frassino naturale. Su richiesta sono disponibili altre essenze e colorazioni customizzate su tinta RAL o PANTONE.

Standard finishing for wood is natural ash. Customized RAL or PANTONE colors are available upon request.

KA 1007

sedia, base a croce girevole, alzata a gas
• aluminum cross swivel base chair, gas lift

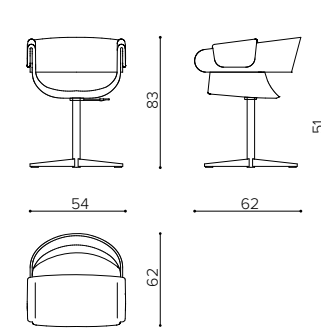
**KA 1008**

sedia, base a croce girevole in alluminio
• aluminum cross swivel base chair

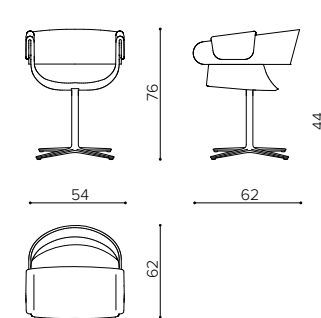
**KA 100C**

sedia, base girevole in alluminio su ruote
• aluminum swivel base chair on casters

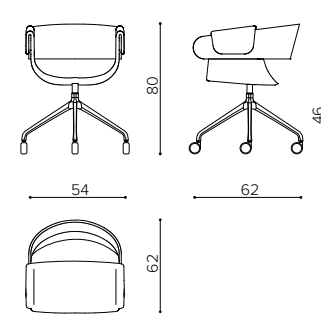
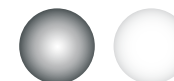
**COLORS****ALLUMINIO / ALUMINUM**

Le finiture standard della base in alluminio sono spazzolato o bianco.

Standard finishings for the aluminum base are polished or white.

MA 1004

sedia a 4 gambe
• 4 legs chair

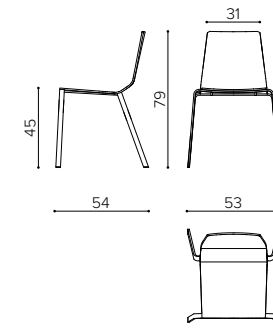
**MA 1054**

sedia a 4 gambe con braccioli
• 4 legs chair with armrests

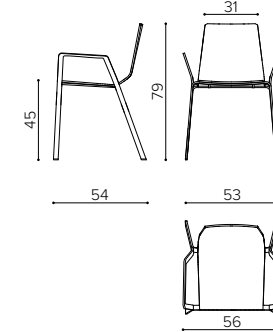
**LEGNO / WOOD**

Le finiture standard del legno sono il rovere e il faggio naturale. Su richiesta sono disponibili colorazioni customizzate su tinta RAL.

Standard finishings for wood are natural oakwood or beechwood. Customized RAL colors are available.

ACCIAIO / STEEL

La finitura standard della struttura in acciaio è bianco o nero opachi. Su richiesta sono disponibili colorazioni customizzate su tinta RAL.

Standard finishing for the steel structure is matte black or white. Customized RAL colors are available.

MP 2000

panca 2 posti · 2 seater bench

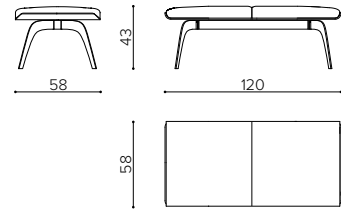
**MP 2100**

panca 2 posti terminale · side 2 seater bench

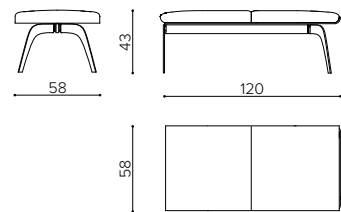
**MP 2C00**

panca 2 posti centrale · central 2 seater bench

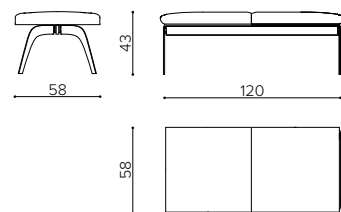
**MP S00R**

elemento "S" destro · right "S" element

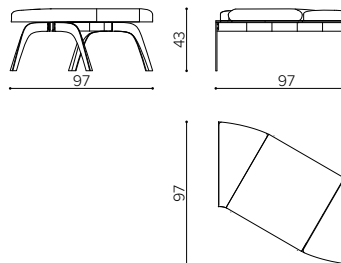
**MP S00L**

elemento "S" sinistro · left "S" element

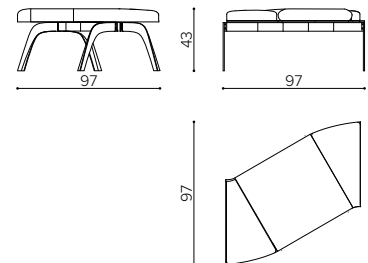
**MP A000**

elemento angolo · corner element

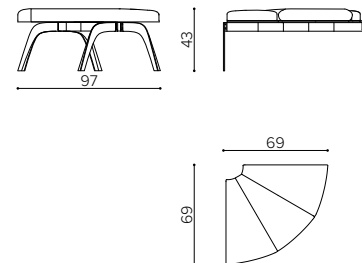
**MP 3000**

panca 3 posti · 3 seater bench

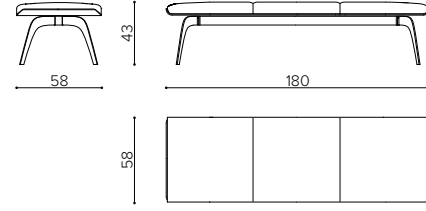
**MP 3L00**

panca 3 posti terminale · side 3 seater bench

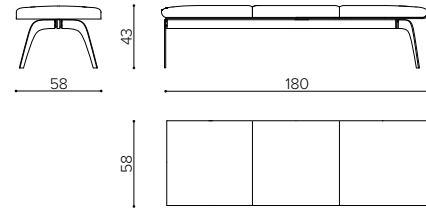
**MP 3C00**

panca 3 posti centrale · central 3 seater bench

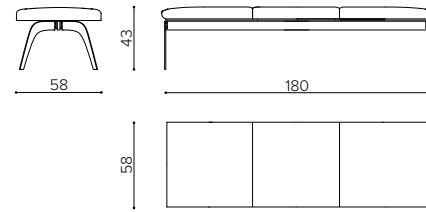
**MP 220W**

schienale 2 posti · 2 seater backrest

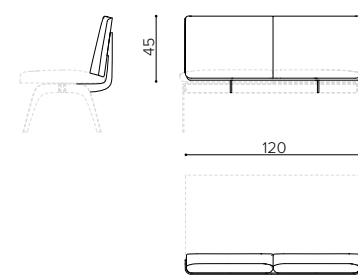
**MP 330W**

schienale 3 posti · 3 seater backrest

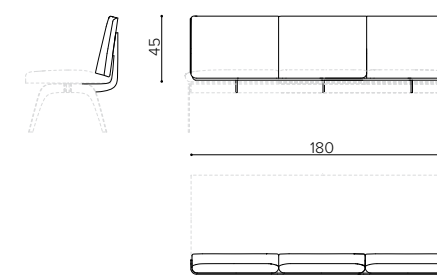
**MP BB00**

bracciolo · armrest

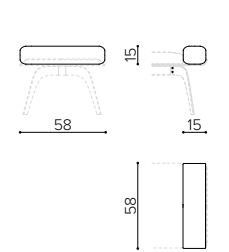
**MP 5POR**

panca circolare · circular bench

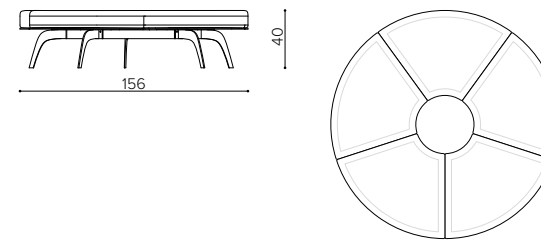
**MP 5POS**

panca quadrata · square bench

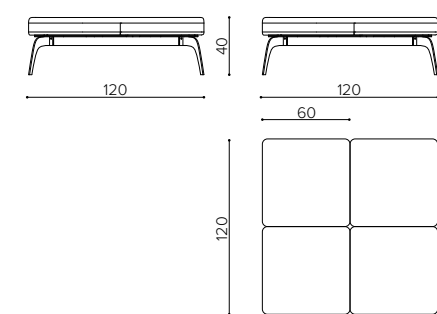
**MP 300H**

divano 3 posti con schienale alto · high backrest 3 seater sofa

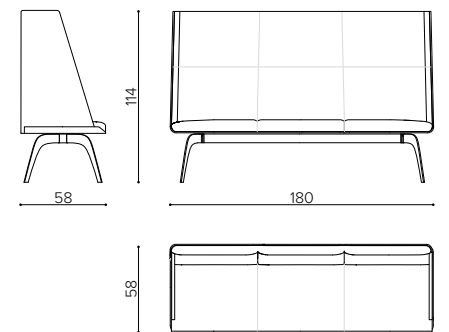
**MP TL0R**

tavolino laterale · side table

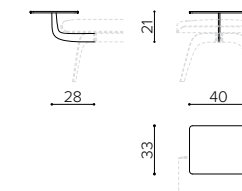
**MP TL4R**

tavolino · table

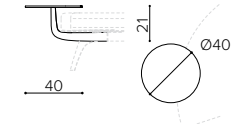
**COLORS****LEGNO / WOOD**

Le finiture standard del legno sono il rovere naturale o tinto all'anilina nero. Su richiesta sono disponibili colorazioni customizzate su tinta RAL o PANTONE.

Standard finishings for wood are natural oakwood or black aniline died oakwood. Customized RAL or PANTONE colors are available upon request.

ACCIAIO / STEEL

La finitura standard della struttura in acciaio è nero opaco. Su richiesta sono disponibili colorazioni customizzate su tinta RAL o PANTONE.

Standard finishing for the steel structure is matte black. Customized RAL or PANTONE colors are available upon request.

NS 1000

poltrona • armchair

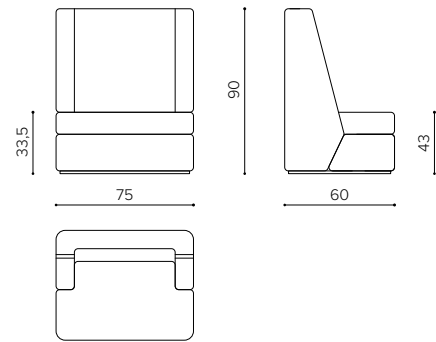
**NS 2000**

divano 2 posti • 2 seater sofa

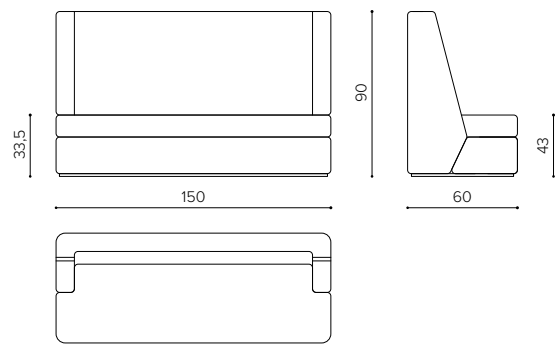
**NS 3000**

divano 3 posti • 3 seater sofa

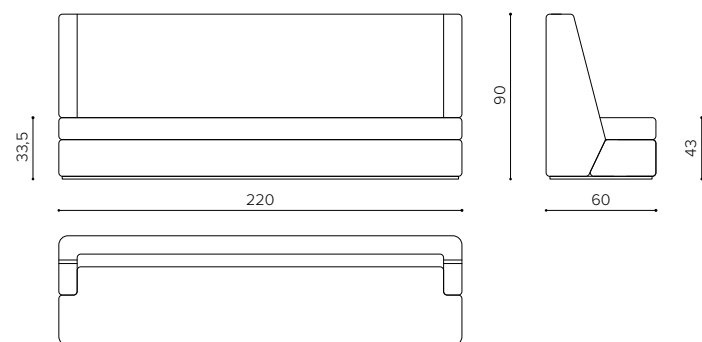
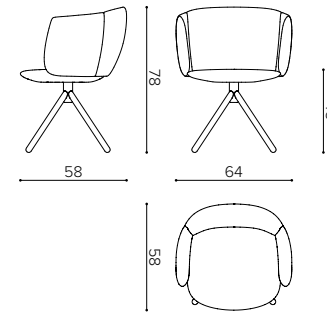
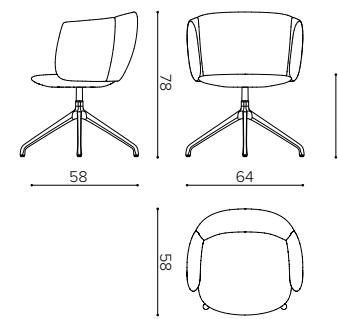
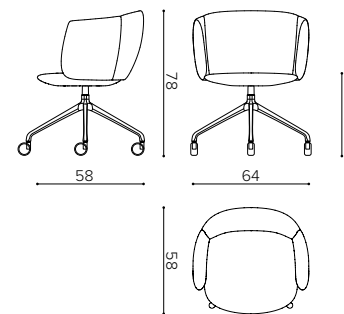
**NT 5090**poltrona con base in acciaio verniciato
• armchair with varnished steel base**NT 5098**poltrona con base in alluminio
• armchair with aluminum base**NT 509C**poltrona con base in alluminio su ruote
• armchair with aluminum base on casters**COLORS****ACCIAIO / STEEL**

Le finiture standard della base in acciaio sono grigio chiaro, grigio antracite, verde o blu. Su richiesta sono disponibili colorazioni customizzate su tinta RAL.

Standard finishings for the steel base are light grey, anthracite grey, green or blue. Customized RAL colors are available upon request.

ALLUMINIO / ALUMINUM

La finitura standard della base in alluminio è il bianco.

Standard finishing for the aluminum base is white.

OR 2000
divano 2 posti • 2 seater sofa

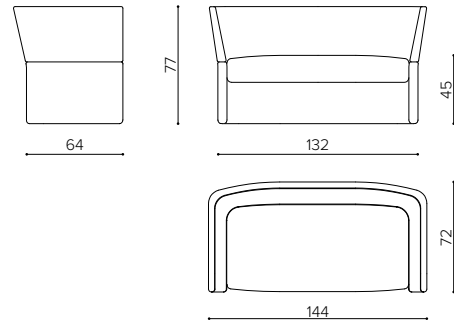

OR 1000
poltrona • armchair

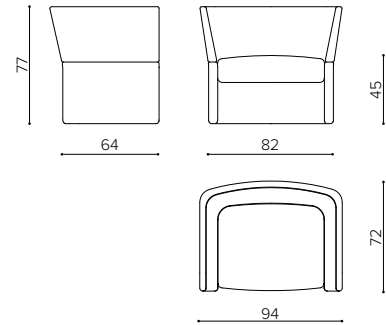

OR 200H
divano due posti alto • high back 2 seater sofa

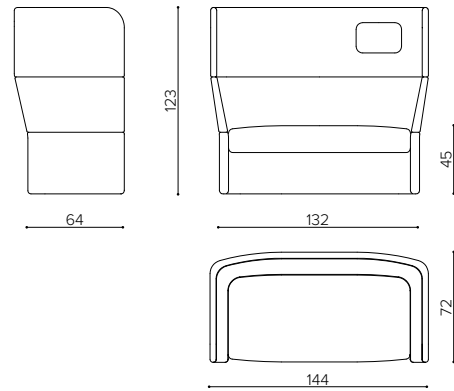

OR 100H
poltrona alta • high back armchair

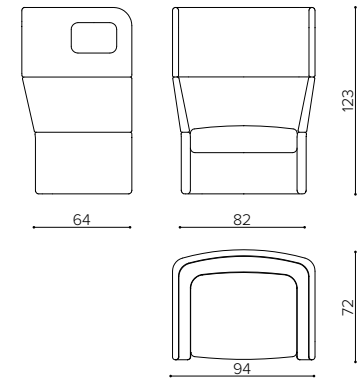

OR A00H
angolo alto • high back angle

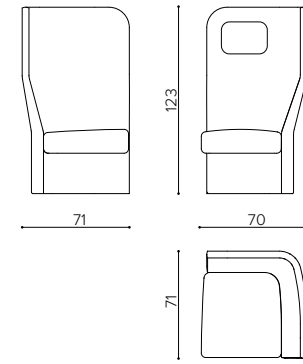

OR D20H
scrivania doppia • double desk

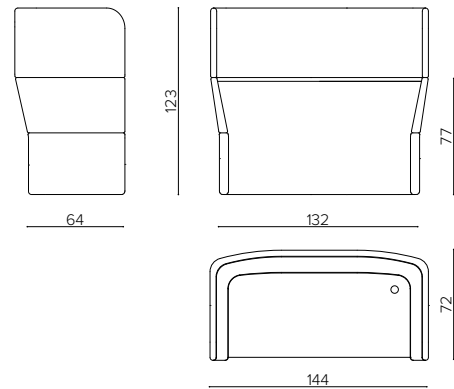

OR B000
panca • bench

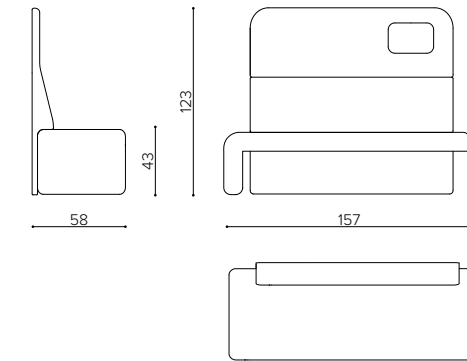

OR P000
pannello basso • low panel

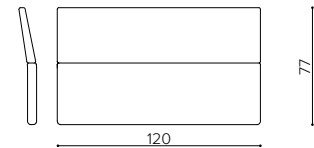

OR P00H
pannello alto • high panel

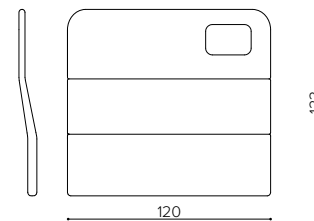

OR FF0H
face to face sofa • divano a sedute contrapposte

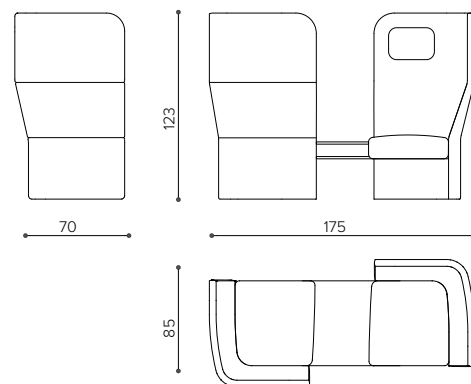

SHIELD
pannello acustico • acoustic panel

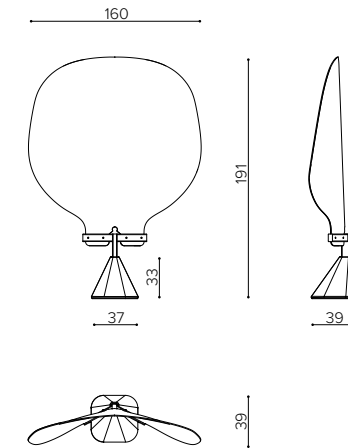

CAP
ombrello acustico • acoustic umbrella

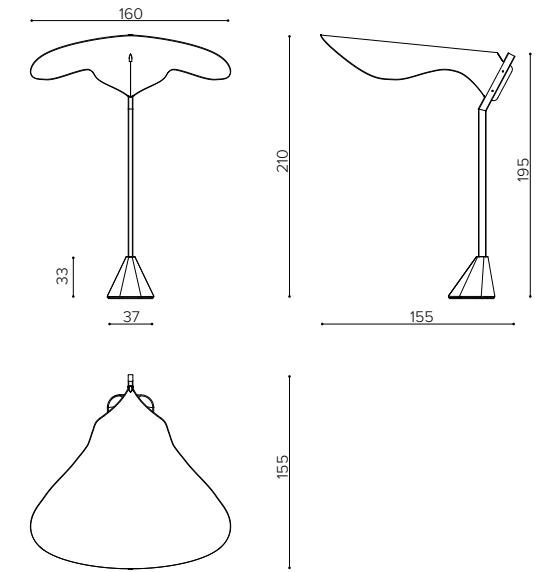

MASK
divisorio acustico da tavolo • table acoustic divider

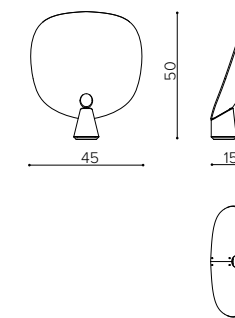

COLORS

PANNELLI / PANELS

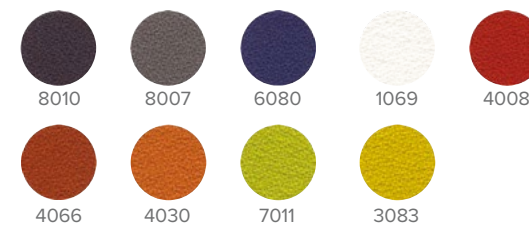

I pannelli PINCETTES sono disponibili in 9 colorazioni standard in tessuto poliestere King Flex Screen. Su richiesta sono disponibili colorazioni alternative.

PINCETTES panels are available in 9 standard colors, in King Flex Screen polyester fabric. Alternative colors are available upon request.

PS 1000

poltrona • armchair

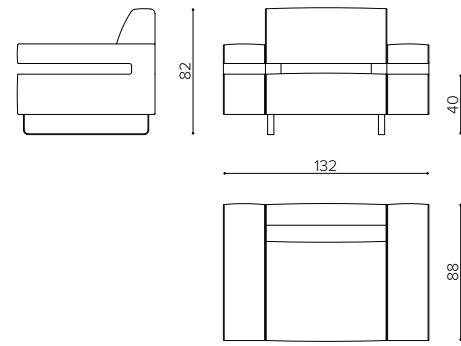
**PS 2000**

divano a 2 posti • 2 seater sofa

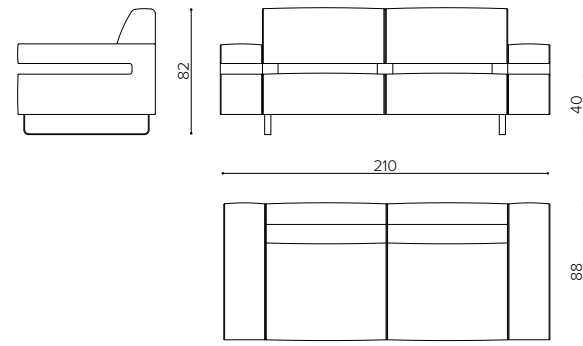
**PS 3000**

divano a 3 posti • 3 seater sofa

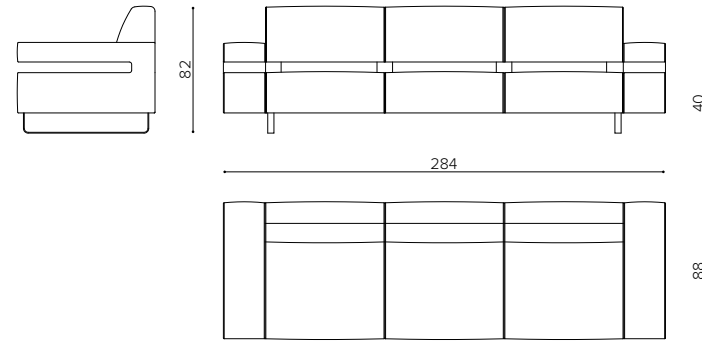
**PS 100M**

poltrona • armchair

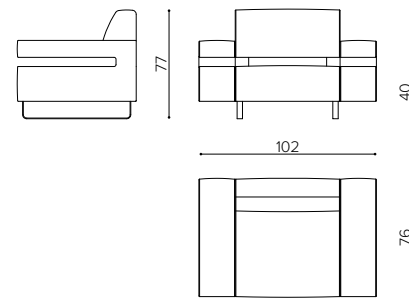
**PS 200M**

divano a 2 posti • 2 seater sofa

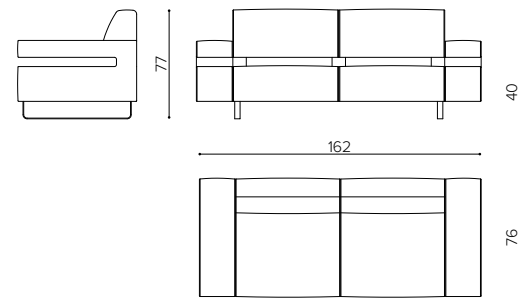
**PS 300M**

divano a 3 posti • 3 seater sofa

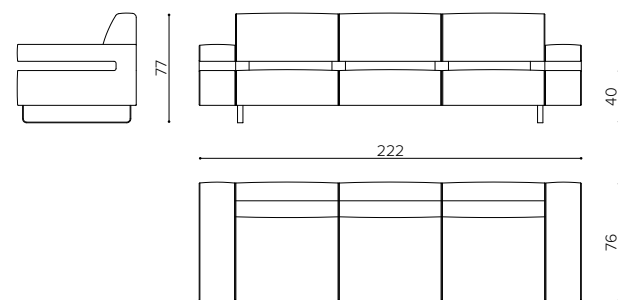
**COLORS****PIEDINI / FEET**

La finitura standard dei piedini è in acciaio cromato. Su richiesta sono disponibili colorazioni customizzate su tinta RAL o PANTONE.

Standard finishing for the feet is chrome steel. Customized RAL or PANTONE colors are available upon request.

SL 1000

poltrona • armchair

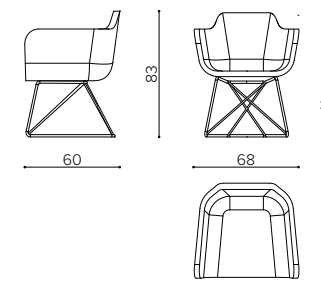
**SL 2000**

divano 2 posti • 2 seater sofa

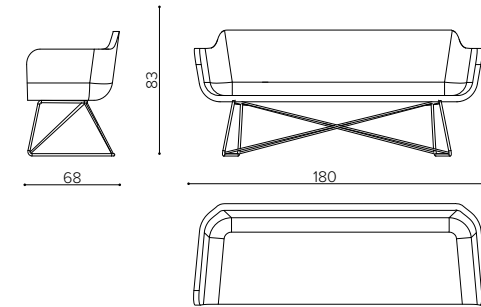
**SL 5000**

divano 2 posti schienale alto • 2 seater high back sofa

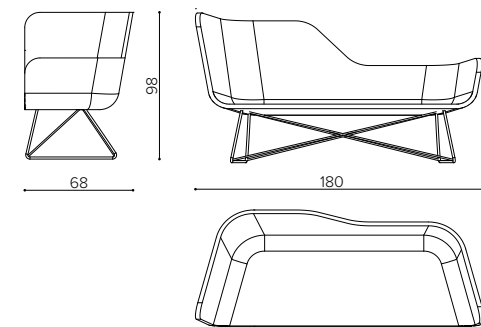
**COLORS****ACCIAIO / STEEL**

Le finiture standard del telaio in acciaio sono cromato o bianco. Su richiesta sono disponibili colorazioni customizzate su tinta RAL o PANTONE.

Standard finishings for the steel structure are chrome or white. Customized RAL or PANTONE colors are available upon request.

WI450

tavolo 450x140 cm · 450x140 cm table

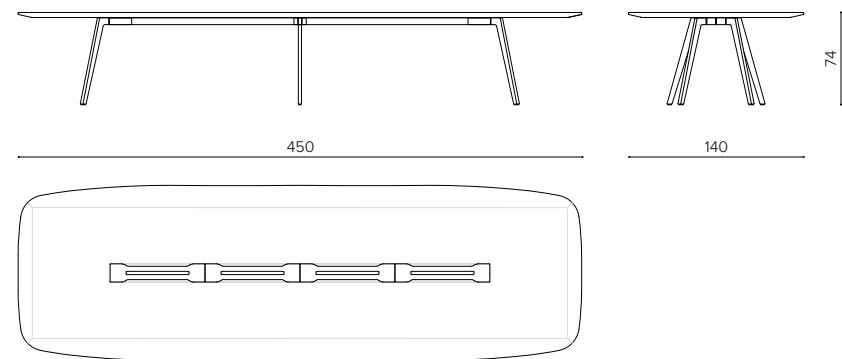

WI320

tavolo 320x120 cm · 320x120 cm table

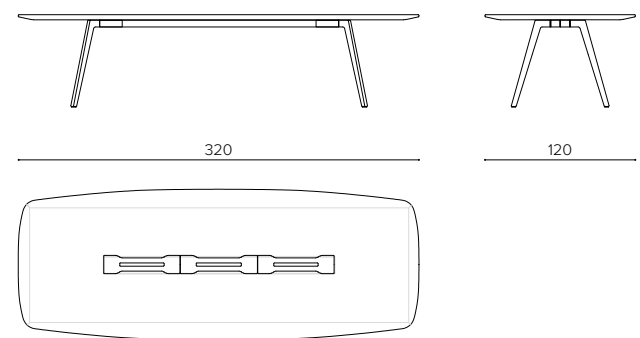

WI220

tavolo 220x110 cm · 220x110 cm table

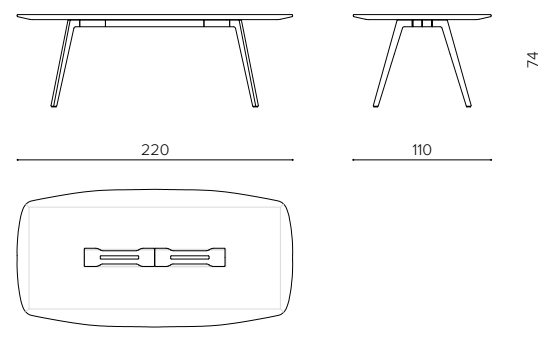

OPZIONI COPERCHI CANALE CENTRALE - validi per tutti i tavoli
CABLE COMPARTMENT COVER OPTIONS - available for all tables

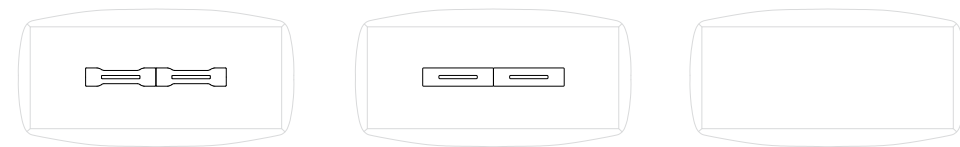

coperchio sagomato
shaped cover

coperchio rettangolare
rectangular cover

piano senza foro
plain top

ACCESSORI / ACCESSORIES

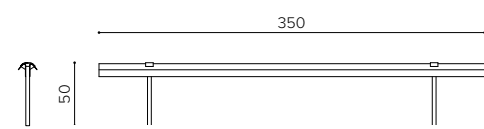

lampada centrale in ottone · brass reading lamp

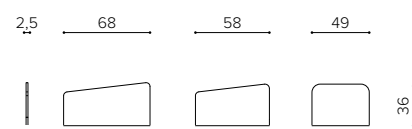

acoustic panels · pannelli acustici

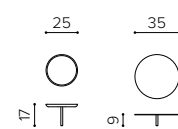

vassoi · trays

COLORS

LEGNO / WOOD



Il piano è disponibile in legno di rovere naturale o noce americano con bordo in massello, in HPL full core bianco o in MDF laccato. Le gambe sono in legno massello, abbinato alla finitura del piano.

The top is available in oakwood or american walnut with solid wood edge, in full core HPL or lacquered MDF. Legs are in solid wood, matching the finishing of the top.

WP 1000

poltrona · armchair

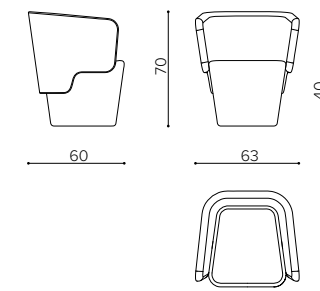

WP 100M

poltrona XL · XL armchair

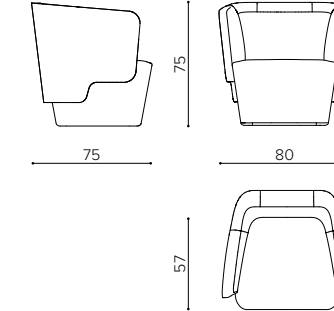

WP 2000

divanetto 2 posti · 2 seater sofa

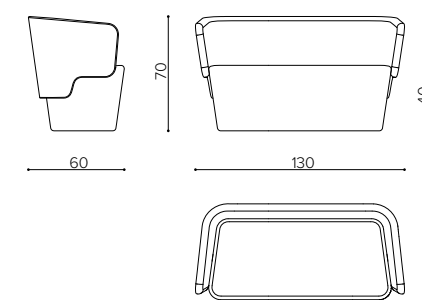

WP 200M

divanetto 2 posti XL · 2 seater XL sofa

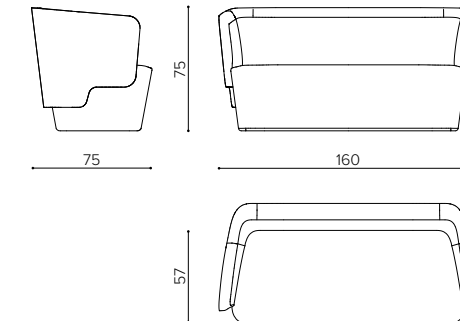

WP 00P

base opzionale anti-ribaltamento · anti-roll extra base



COLORS

ACCIAIO / STEEL



La finitura standard della base opzionale è grigio antracite. Su richiesta sono disponibili colorazioni customizzate su tinta RAL o PANTONE.

Standard finishing for the optional base is dark grey. Customized RAL or PANTONE colors are available upon request.

DESIGNERS



DEBORA MANSUR
www.deboramansur.arq.br



LUCIANO DELL'OREFICE
www.luciano-dellorefice.com



P+F PARISOTTO+FORMENTON
www.studioparisottoeformenton.it



FAVARETTO & PARTNERS
www.favarettoandpartners.com



CHRISTOPHE BOURBAN
www.christophebourban.com



E-GGS DESIGN
www.e-ggs.it



LEONARDO ROSSANO
www.leonardorossano.com



ORLANDINI DESIGN
www.orlandinidesign.net



AVIO CALANDRIN
www.designitalia.it



EUGENIO FARINA
www.designitalia.it



IRODABÚTOR

4026 Debrecen, Hunyadi utca 8.

(Class Design)

Fax. +36 52 524 541

Mobil. +36 30 336 0699

Email. vivax@vivax.hu,

tervezes@vivax.hu www.vivax.hu

3525 Miskolc, Széchenyi utca 7.

(Pátria üzletház 1. emelet)

Fax. +36 46 413 921

Mobil. +36 30 903 9255

Email. vivaxmiskolc@vivax.hu

2045 Törökbálint, Tópark utca 1/a.

(MaxCity Lakberendezési Áruház, II. em. 232. ID Design)

Fax. +36 23 444 708

Mobil. +36 30 968 5232

Email. budapest@vivax.hu



www.facebook.com/vivaxiroda